

County of Middlesex

Tourism Signage Strategy

Final Report • March 2013

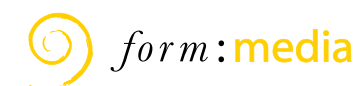

Contents

- 1.0 Introduction.....4**
 - 1.1 Goals of the Middlesex County Tourism Signage Strategy.....4
 - 1.2 Background4

- 2.0 Visual Identity Recommendations5**
 - 2.1 Colour Standard Recommendations5
 - 2.2 Typeface Standard Recommendations.....5
 - 2.3 Visual Vocabulary.....6

- 3.0 Proposed Sign Elements8**
 - 3.1 Preliminary Signage Hierarchy.....8
 - 3.2 Best Practice Recommendations for Vehicular Signage Design.....9
 - 3.3 Existing Gateway Signage on Highway 4019
 - 3.4 Signage Designs 10

- 4.0 Route Recommendations 14**

- 5.0 Sign Location Recommendations..... 18**
 - 5.1 General Recommendations for Vehicular Signage Placement 18
 - 5.2 Signage Location Criteria 19
 - 5.3 Signage Location Maps.....22

- Appendices.....56**
 - Design Fabrication Specifications and User Manual

1.0 Introduction

1.1 Goals of the Middlesex County Tourism Signage Strategy

The goals of the Middlesex County Tourism Strategy are to:

- provide a clear, methodical sequence of identification and tourism-based directional signage elements for visitors and residents.
- ensure guidance between and throughout the County through visually intuitive signage designs and consistent messaging, .
- define a route through the County that will bring several small tourism venues together to create a larger tourism package, resulting in tourists staying longer and spending more.
- provide local tourism-based businesses with a quality pay-to-play option for signage that is inclusive and complements both the needs of the business owner and the County.

Consideration is also be given to a sustainable design approach that streamlines the number and type of signs required. As the project progresses, recommendations will be developed that will permit stakeholders to easily revise/amend sign elements to reflect current wayfinding needs.

Despite the recent adoption of new GPS based wayfinding tools, directional signage is still the most efficient, familiar and accessible method of guiding visitors to a desired destination. It can also help them find destinations, services or attractions they didn't even know were there. A signage system of this nature will also provide the County with the most cost effective wayfinding solution. Related graphic devices such as maps, handouts, web-based resources are all elements of a successful wayfinding strategy that should be considered as needs are defined and budgets become available. Uniformity within these items with the physical wayfinding system must be consistent to ensure its success.

1.2 Background

The County of Middlesex is an upper-tier municipality comprised of eight local municipalities:

- the Township of Adelaide Metcalfe
- the Township of Lucan Biddulph
- the Municipality of Middlesex Centre
- the Municipality of North Middlesex
- the Municipality of Southwest Middlesex
- the Municipality of Strathroy-Caradoc
- the Municipality of Thames Centre
- the Village of Newbury

This phase of the wayfinding initiative is primarily directed towards establishing an approved signage hierarchy and identifying potential signage locations within Middlesex County.

Specifically, this report addresses the following:

- Existing wayfinding signage review
- Preliminary signage hierarchy recommendations
- Preliminary signage design and location recommendations

NOTE:

All sign placement recommendations within this document are intended to be approximate only. Prior to installation, all sign locations shall be reviewed and adjusted as needed by the client's sign production team to meet all applicable guidelines and bylaws for each location. Site verification by the client is required for final locations of signs. Form:Media will not be responsible for finalizing any locations.

2.0 Visual Identity Recommendations

The Middlesex brandmark should be applied cohesively across all published information about the County, whether in print or electronic form, as well as signage. Adherence to a consistent application of the brand will foster a unique and recognizable identity.

The signage system should not only apply the Middlesex brandmark consistently but also adopt the following visual recommendations to ensure an effective and identifiable user experience.

EXISTING LOGOS



2.1 Colour Standard Recommendations

The Middlesex brandmark colour palette provides the foundation for the colours used in the tourism signage strategy. Additional secondary colours have been introduced to compliment and expand this palette. Pantone and CYMK values are shown below.

PRIMARY COLOUR PALETTE (BASED ON EXISTING LOGO)



PMS: 294 C
 CMYK: 97 69 10 1
 RGB: 0 91 157
 WEB: #005B9D



PMS: 363 C
 CMYK: 83 18 100 4
 RGB: 38 147 30
 WEB: #269346



PMS: 110 C
 CMYK: 0 12 100 7
 RGB: 241 203 0
 WEB: #F1CB00

SECONDARY COLOUR PALETTE



PMS: 7499 C
 CMYK: 2 3 25 0
 RGB: 251 241 199
 WEB: #FBF1C7

2.2 Typeface Standard Recommendations

The following type face option recommendations are based on criteria aiding in high visibility in vehicular scenarios:

- stays within appropriate stroke-to-width ratios
- san-serif characters
- simple characters

PRIMARY TYPEFACE

Clearview Highway 2-W
 abcdefghijop 123 AQ

2.3 Visual Vocabulary

2.3.1 EXISTING INSPIRATIONS

There is a prevalent rural vernacular style that can be seen driving along the roads of Middlesex County. The vernacular draws from rural and farm built works including corrugated steel grain silos, rustic fences and windmills, weathered barns, and Ontario homesteads detailed with yellow brickwork, intricate lattice details, and steep roof pitches.

It is important that the final design implementation of Middlesex's signage system draws inspiration from and does not visually compete with these vernacular elements. Describing the vernacular visual vocabulary helps to serve as inspiration for the final sign designs and has been carried through to the three design concepts presented in this report.

Shown are some examples of these details taken as inspirational imagery used in the design process to create signage integral to this rural scenery.



- Windmills, fences, farm equipment
- Rustic texture and material
- Angles, intersecting lines, and shapes



- Yellow brick and stonework
- Intricate lattice details
- Steep roof pitches



- Corrugated metal
- Raw materials
- Verticality
- Hopper shape



- Rough barnwood
- Natural weathering
- Bright colour & geometry of quilts
- Contrast of between quilts & barns
 - Bright vs. drab
 - Geometric vs. organic
 - Naturally weathered vs. painted

2.3.2 OTHER INSPIRATIONS

The translation of the visual vocabulary into a rational design intent is the precursor to the design conceptualization phase.

Below are some examples of signs, textures, materials, and general ideas taken as inspirational imagery used in the design process to create signage integral to this rural scenery. These styles were discussed and coordinated with the steering committee prior to commencing the 3 design concepts.



- Corrugated metal
- Corten steel
- Timber frame
- Natural materials contrasting with painted elements



- Corrugated metal
- Corten steel
- Timber frame
- Natural materials contrasting with painted elements



- Retro feel
- Grassroots, 'country' feel



- Corrugated metal
- Simple, elegant layering of materials
- Geometric patterns reminiscent of the barn-quilt motif



- Corrugated metal
- Simple, elegant layering of materials
- Geometric patterns reminiscent of barn-quilt motif



- Retro feel
- Grassroots, 'country' feel
- Weathered

3.0 Proposed Sign Elements

3.1 Preliminary Signage Hierarchy

In August 2012, Form:Media staff completed a comprehensive audit of existing signage and vehicular circulation routes. The resultant proposed sign hierarchy for Middlesex was confirmed through an invited stakeholder workshop session where the groups distilled a list of required sign types. Please refer to Appendix A for details regarding sign design criteria and placement guidelines.

Gateway Signage

COUNTY GATEWAY SIGN – PRIMARY

These signs welcome visitors to the County of Middlesex and distinctly identify the County. They are positioned near County boundaries on County-maintained roads of high traffic volumes or used as the tourism route.

COUNTY GATEWAY SIGN – SECONDARY

Positioned at secondary points of entry (i.e. on arterial county-maintained roadways into the County) these signs identify Middlesex and supplement the Primary Gateway Signs.

LOWER TIER MUNICIPAL GATEWAY SIGN*

These signs allow lower tier Municipalities to uniquely identify themselves on direct entry routes within their respective Municipal boundaries. Middlesex County will also be identified on these sign types.

COMMUNITY GATEWAY SIGN*

These signs allow Communities to uniquely identify themselves on entry routes within the respective Community boundaries, and tie in with the overarching County aesthetic.

Themed Route Signage

ROUTE INTRODUCTION

These signs are located at major entry points to the Grassroutes and display a simple route map.

ROUTE ASSURANCE MARKERS

These signs provide route assurance by displaying the route name and route icon on roadside sign markers.

ROUTE DIRECTIONAL

Similar to the route assurance markers, these signs feature a directional arrow and will be positioned at major decision points.

Identification Signage

MUNICIPAL AMENITY IDENTIFICATION*

Tying in with wayfinding signage system to ensure user recognition, these sign units will identify municipal buildings, as well as amenities (e.g. parks and trails).

PARKING IDENTIFICATION*

These sign types are designed to identify specific parking areas within downtown areas.

HERITAGE RIVER IDENTIFICATION*

These signs identify geographic features that are recognized for their natural heritage, such as the Thames River.

Information Kiosks

INFORMATION KIOSK – VEHICULAR

It is proposed that *Primary Information Kiosks* will be located at natural stopping points at the primary entry point into the County from the Highway 402. These units provide orientation maps and directional information as well as details about local amenities for the immediate area or community. A QR code will provide a web-link for supplementary or additional information.

INFORMATION KIOSK – PEDESTRIAN

These units will provide orientation maps and related information in areas where larger kiosks are impractical and/or within pedestrian areas. Content will pertain to downtown attractions and nearby amenities.

Directional Signage

PUBLIC DESTINATION DIRECTIONAL – RURAL

Where there is a gap in the existing provincial signage, these sign types will provide vehicular directional information to public County-wide attractions and points of interest.

PUBLIC DESTINATION DIRECTIONAL – URBAN

These signs provide vehicular and pedestrian-level directions to destinations within downtown areas.

Directional Signage (cont.)

COMMUNITY ASSURANCE SIGNS

These signs provide assurance to motorists that they are on the correct route by displaying the name and distances, of up to three significant downstream communities, which the freeway passes near or through.

PARKING DIRECTIONAL*

These sign types direct motorists to parking areas within downtown cores.

PAY-TO-PLAY SIGNAGE

These modular sign units have been designed to provide directory information for private tourism-based businesses. A maximum of 4 destinations is recommended per sign unit. Administration, fabrication, installation and maintenance of these sign units has yet to be confirmed.

Ancillary Signage

INTERPRETIVE PANELS* (Barn Quilt Sites and/or Heritage Sites)

These elements depict unique and engaging stories specific to the County of Middlesex. It is recommended that a QR code is included to allow access to additional information if applicable.

INTERPRETIVE MARKERS* (Barn Quilt Sites and/or Heritage Sites)

These signs are positioned at specific points of interest, such as **Barn Quilt Sites**, as simple visual markers. QR codes will provide links to online content.

SERVICE CLUB SIGNS*

These signs are typically installed at the approach to a community and have the potential of furthering a strong positive image for the area. Annual maintenance is often deferred resulting in signs that look deteriorated, and it is therefore recommended that a clean, modern design is adopted.

* These signs are optional and can be implemented on a voluntary basis.

3.2 Best Practice Recommendations for Vehicular Signage Design

The tourism way-finding system will address primary tourist requirements and be developed to conform to the fundamental 'rule following' concept of all way-finding systems - where the user simply obeys directions, from an entry point to a final destination.

In the development of the system, effective graphic communication shall be utilized. Graphic elements such as consistent colour coding, fonts and maps, provide points of orientation, direction, and identification. Effective graphic communication in our past way-finding systems was achieved via a combination of the following graphic conventions:

- minimized use of text
- easily understood language (where used)
- the use of colour as a 'type' key
- the use of memorable graphics
- the use of established pictographs in relation to universal understanding
- the use of custom pictographs in relation to established themes specific to the area
- utilization of a typeface that is designed to be read from a prescribed distance
- utilization of colour contrast greater than 70% to ensure best visibility
- reduce the number of required sign elements
- reduce waste in the fabrication process with cost savings as a by-product
- incorporate modular systems where applicable, for future cost-effectiveness
- address the requirements of the mobility and visually challenged to create an all-inclusive signage system.

3.3 Existing Gateway Signage on Highway 401 & 402

Currently there are two sites on the 400 series highway where Middlesex County gateway signs have been installed based on a previous design style. A rendering of the sign design is shown below.



Above: Existing 400 series highway sign, designed by others.

The following preliminary signage designs have taken this gateway sign into consideration and feature similar elements, such as the three dimensional letters and logo elements. This underscores the importance of having a cohesive sign system that users can easily identify and become familiar with.

3.4 Signage Designs

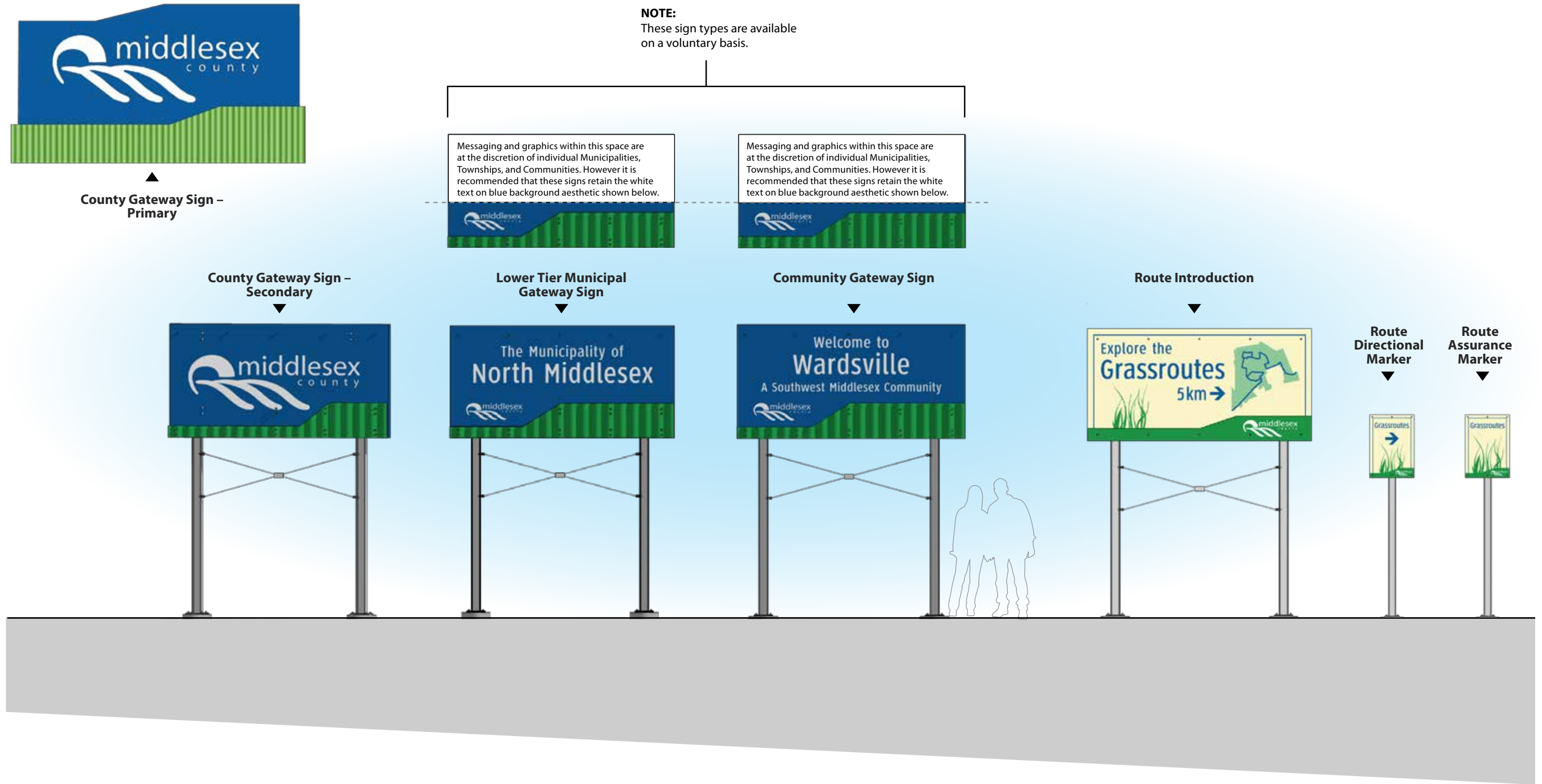

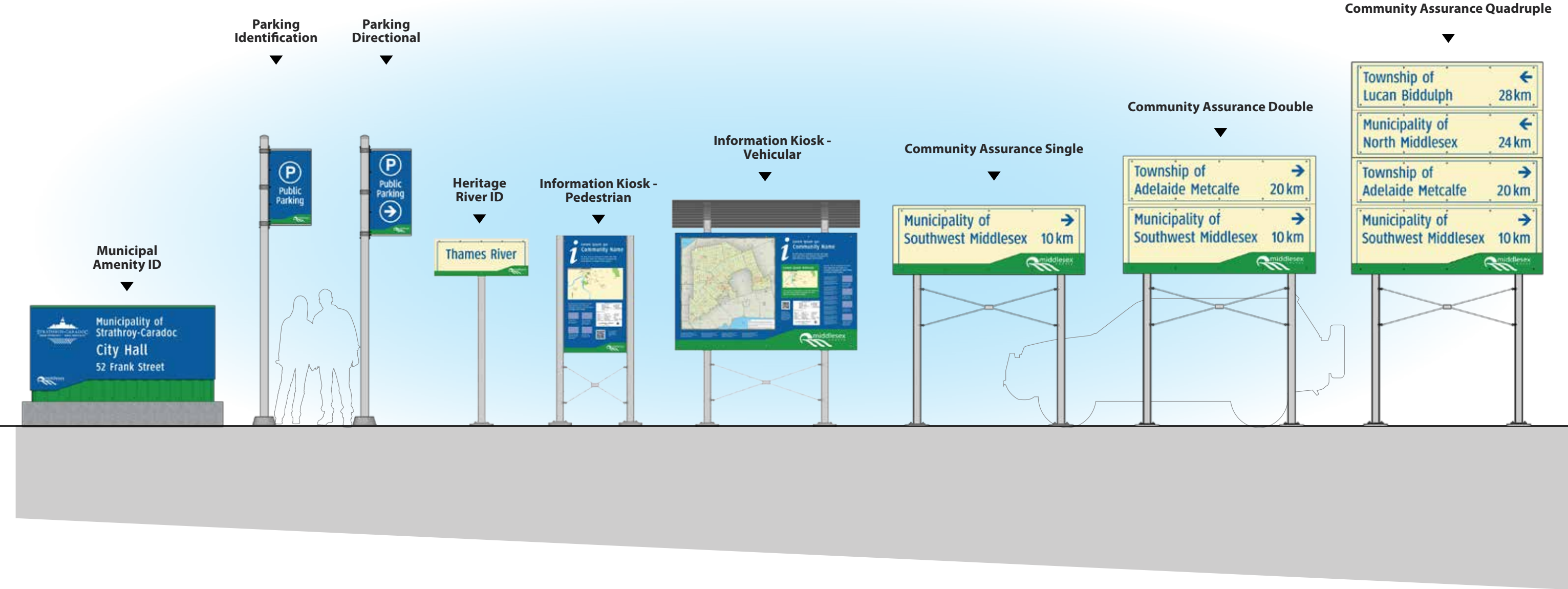

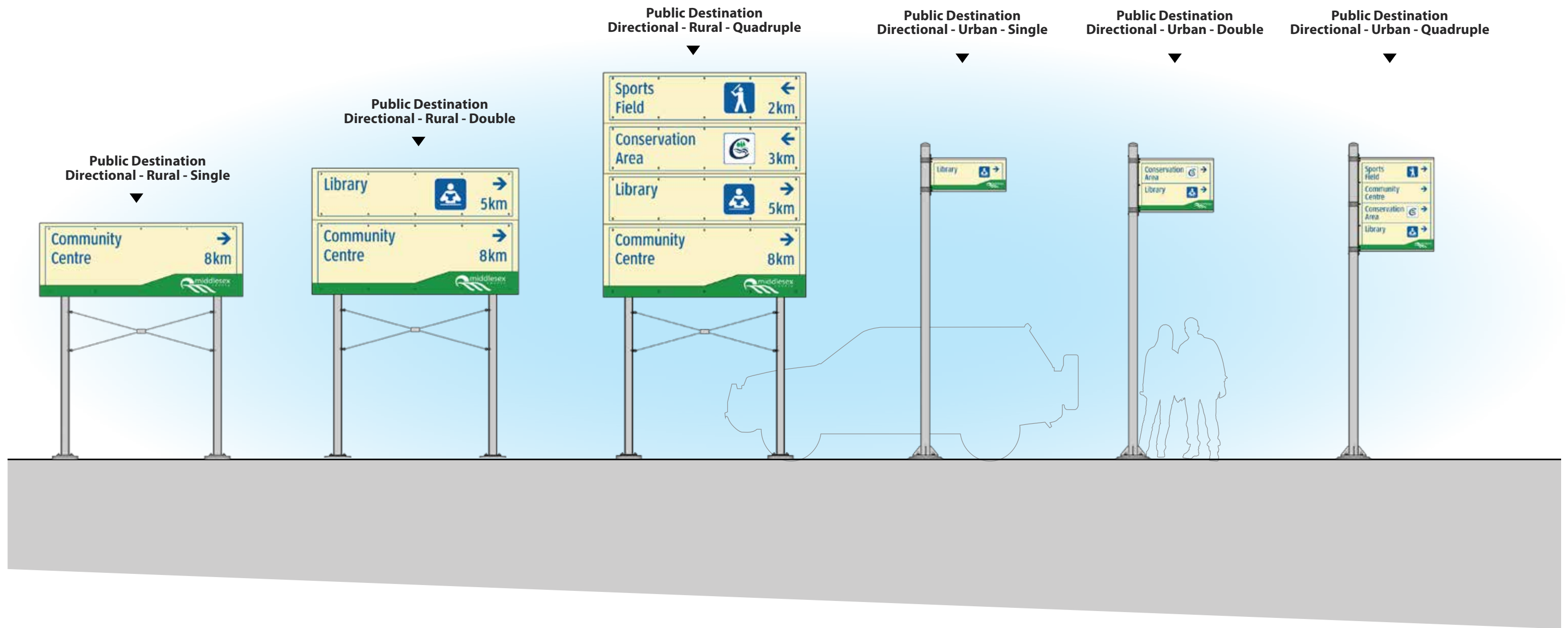

NOTE:
Pay-to-Play users shall have the option to use their own logo instead of a pictogram, on the condition that the logo appears in blue and white and fits within the 15" x 15" space.

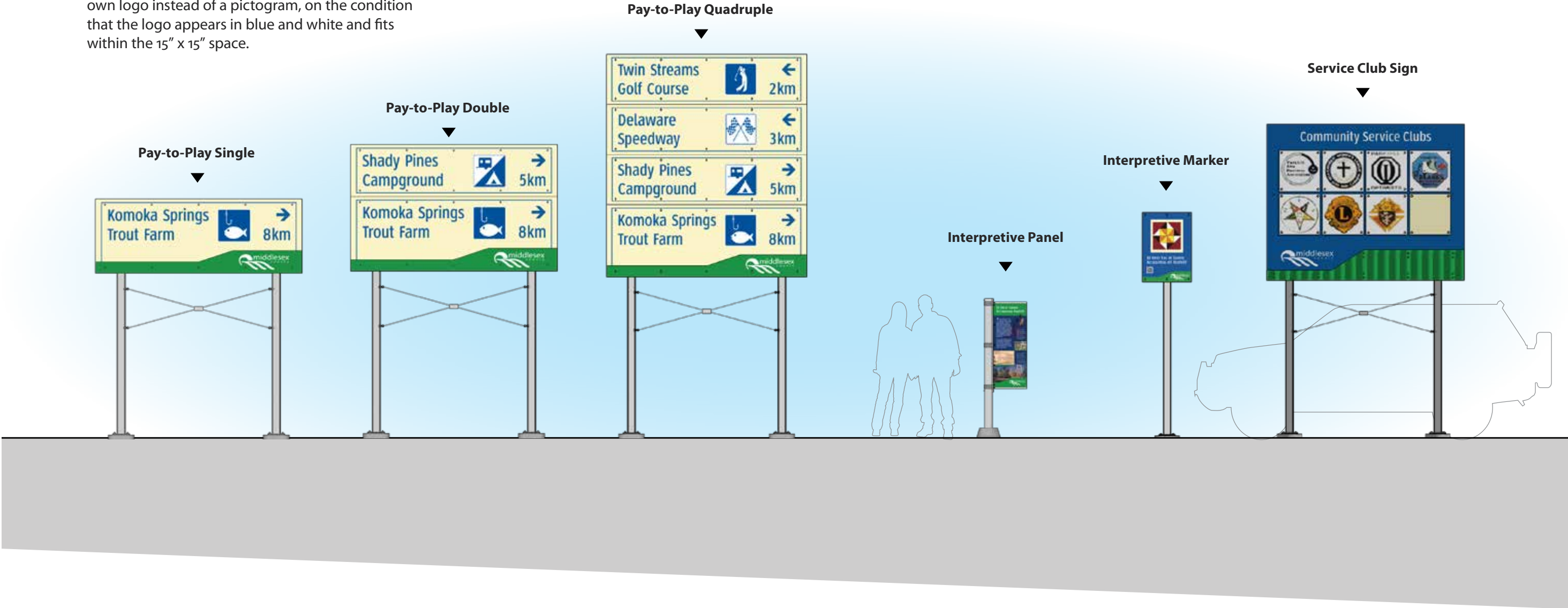

4.0 Route Recommendations

A Route for Middlesex County: “Grassroutes”

One primary tourism route is proposed to guide travellers (locals and visitors) through Middlesex County’s unique collection of communities, landscapes, and attractions, supported by three smaller loops (see Proposed Route Map in this section). This route suits the County’s overall size, road system, and volume/location of available tourism products and attractions. It has been developed in line with current tourism planning thinking and the shift toward experiential travel, while maintaining a sense of what is distinct and unique to Middlesex County, and is proposed for the following key reasons:

- The highest concentration of tourism products and attractions in the County is located along the proposed primary route; travellers can be directed to key tourism products and attractions not located on the primary route (but accessible from it) using wayfinding elements.
- Many of the County’s communities can be reached via the proposed primary route (i.e. access to the proposed primary route is available throughout the County).
- The proposed primary route is appropriately distributed throughout the County, ensuring that no one community is over (or under) travelled by the route.
- The proposed primary route has the potential to act as the main link to future RTO1 route development, as part of a larger multi-county tour.
- Proposed roads are maintained by the County, and eligible for sign placements without requirement of outside permissions.
- Stakeholder feedback.

Building on ideas generated at the August 2012 workshop, this proposed primary route will encompass the following types of experiences currently offered in Middlesex County:

- **Culture & Heritage**
An authentic glimpse into Middlesex County’s lived experiences, from the earliest roots to the latest in local arts and culture (e.g., barn quilt locations, artisan studios, historic places, etc.).
- **Adventure & Escape**
Lush Carolinian forests, natural wonders, and a fantastic lineup of activities for travelers ready to make the perfect escape (e.g., hiking, horseback riding, camping, etc.).
- **Food & Tradition**
Home-grown flavours, culinary communities, and the legacies left by those who first put down roots along these wandering roads (e.g., u-picks, greenhouses, farm markets, etc.).

The name selected for the proposed primary route should embrace these types of experiences, creating an immediate sense of what the route is “all about” and what visitors can expect if they choose to travel it. It is recommended that the proposed primary route for Middlesex County not end with “Trail” to avoid confusion with other well-established initiatives in the area that use this suffix (e.g., Heritage Trail, Barn Quilt Trail).

Below is the proposed name for the primary tourism route.

Grassroutes

After reviewing the criteria and shortlisting three names, this name was chosen by the Middlesex County Tourism Wayfinding Signage Steering Committee, by way of consensus.

Other options not chosen: Harvest Way, Wildwood Way

Naming for the three proposed loops should support, rather than compete with, the naming proposed for the primary route (i.e. Grassroutes). For this reason it is not recommended to name these loops thematically (e.g., Donnelly Loop, Harvest Loop, etc.). Instead it is suggested that each loop be identified based on the Municipality that they are in (i.e. Lucan Loop, North Middlesex Loop, etc.).

Applying the same design aesthetic to signage for the loops will ensure that travellers understand that these smaller loops are part of the primary route travel experience.

PROPOSED ROUTE MAP

One primary tourism route is proposed to guide travellers (locals and visitors). For jurisdictional purposes, an effort has been made to align the route with only those roads that are owned by the County. Roads were selected with consultation of the County Roads department to ensure all roads on the route were best for safety, visibility and navigation.

The proposed loop through Lucan will require the cooperation of the Province, MTO, and/or Municipality to incorporate signage on the route in that area.

The map shown delineates the best route based on these criteria while aiming to hit as many towns along the way (as requested by stakeholders). Stakeholder feedback accumulated following early drafts of this route, including the comments below, has been integrated into the final map shown here.

"...the route should go from Wardsville down Longwoods, through Mt. Brydges and Strathroy, up to Parkhill, and then to Ailsa Craig and Lucan...down to Ilderton, Arva, over to Thorndale, and across to Dorchester."

"...a route coming east from Parkhill, as opposed to north and then east, so that the route will pass through Ailsa Craig...where there are 7 locations for the Middlesex Heritage Trail, and a museum. It will also allow us to hit the traffic along #7..."

"Criticisms of missing this and that are failing to realize the goal of the route, and that signage will point people to excursions off the route."

"...although Delaware is our biggest tourism attraction, it is also seasonal...highway 81 which drives the visitor right through Mt. Brydges and into Strathroy where our own Heritage Trail and largest community in our county is located."

"I think hitting Parkhill is important but, if we can find a way to pull it back from the north border and hit a few of the heritage (quilt, etc.) spots in Ailsa Craig..."

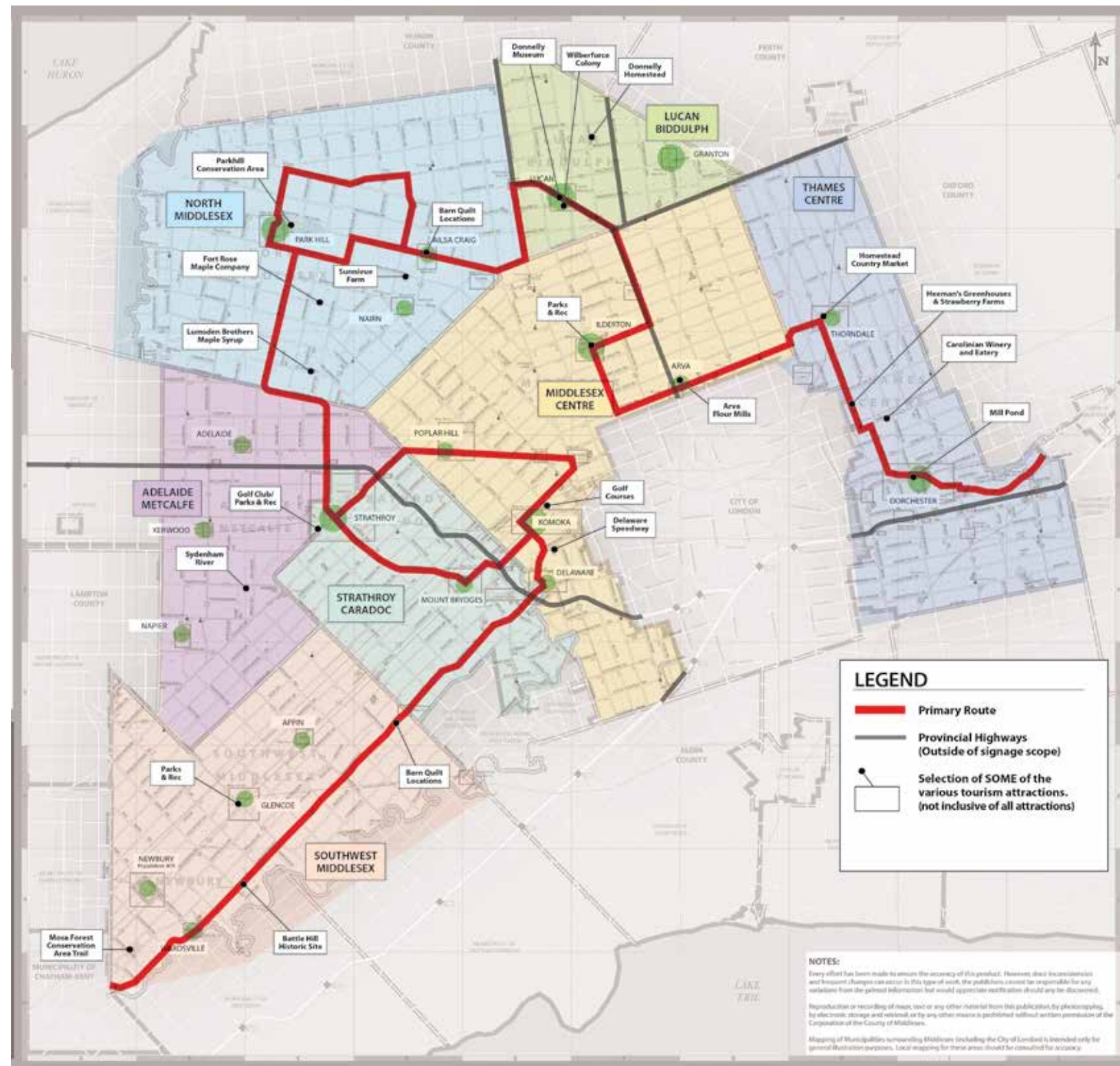

EXISTING TRAFFIC COUNTS

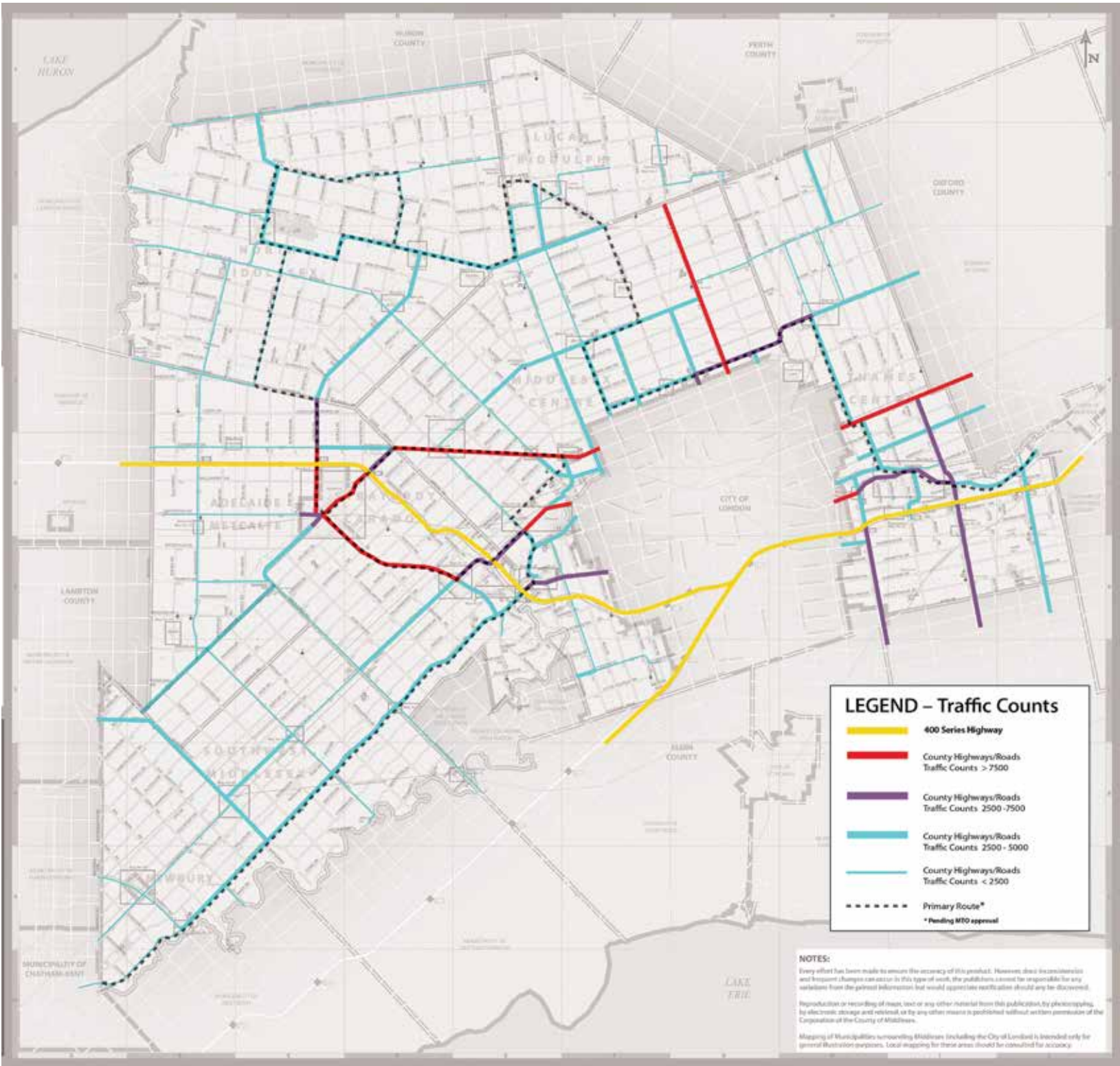

EXISTING ATTRACTIONS

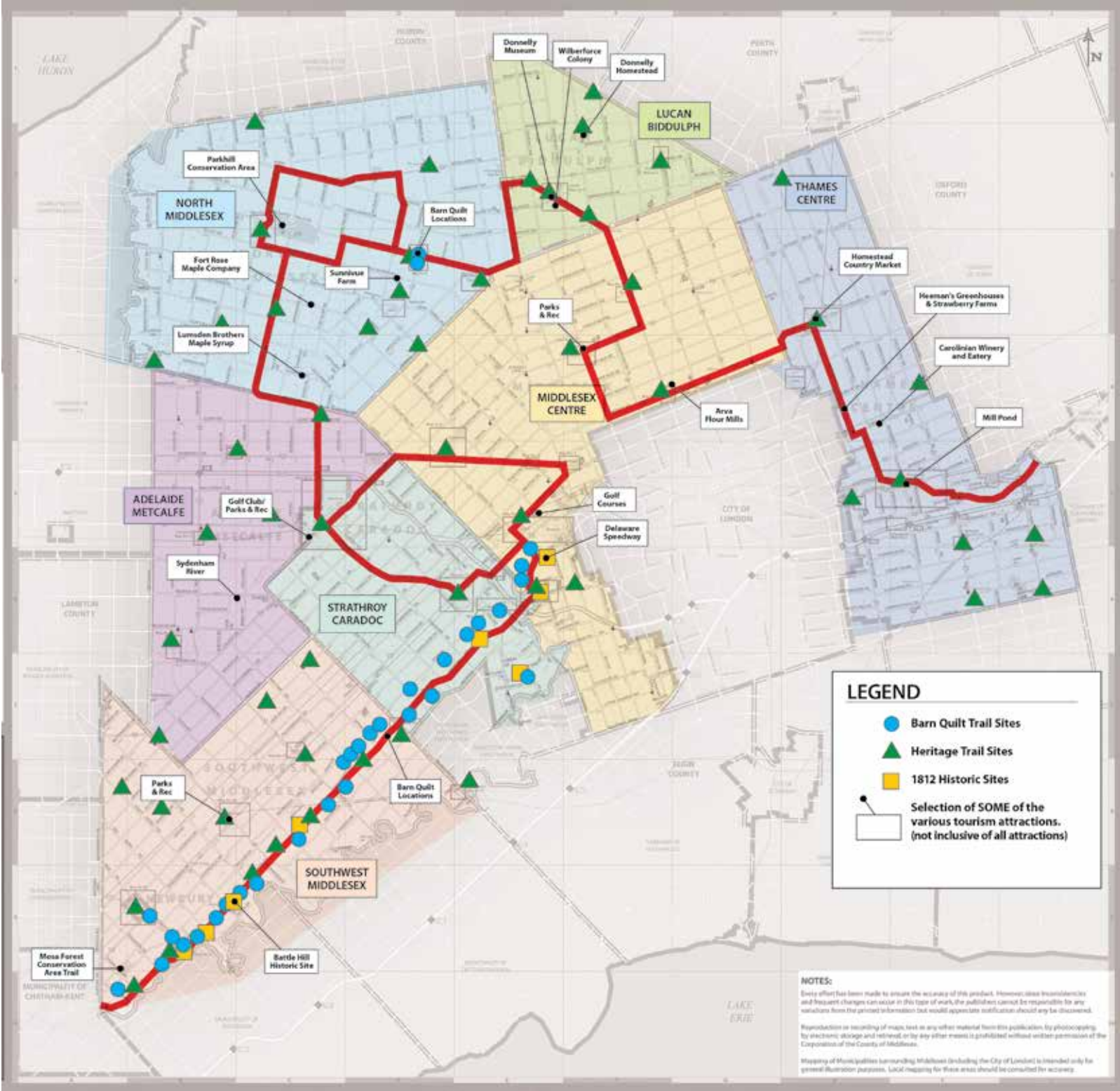

5.0 Signage Location Recommendations

In August 2012, Form:Media staff conducted a comprehensive sign audit of the County of Middlesex. The audit examined existing municipal- and county-based identity and directional signage, and vehicular circulation patterns. This activity provided insight into primary entry routes and tourism travelways. In tandem with this information, existing signage levels were examined to determine if they are adequate to their design and purpose.

These details have been combined to form the following sign location recommendations. This section provides insight into where new wayfinding and identity elements are required to complete an effective signage program.

From a tourism wayfinding perspective, the goal of the signage is to direct traffic through the County and deter short-cuts through London. The signs shall aid in direction to the Tourism Route, as well as direct to key attractions from the Route out into the County.

5.1 General Recommendations for Vehicular Signage Placement

- Adhere to applicable by-laws and provincial regulations
- Avoid clustering several signs in one place. This will detract the eye from focusing on important information.
- No sign should be placed in such a way that it obscures another sign behind it in such a way that the sign behind is no longer viewable within its required time frame per distance/speed formula calculations.
- When possible, adjacent gateway should be combined (ex. one gateway recognizing entering a boundary to the County and the amalgamated community rather than two signs in close proximity. This creates less visual clutter, and is more cost effective.
- Directional signs should be placed at integral decision points along a given travel route.
- Gateway signs should be placed within close proximity to the boundary in which the sign is introducing.

5.2 Signage Location Criteria

Type	Description	Design Criteria	Form:Media Recommendations	*Relevant Guidelines from the Ontario Traffic Manual (OTM), Book 8, Volume 1
COUNTY GATEWAY SIGN - PRIMARY	These signs welcome visitors to the County of Middlesex and distinctly identify the County.	<p>Message is restricted to the name of the community and/or an approved municipal logo or slogan. Internet addresses, telephone numbers, and other similar messages are not permitted.</p> <p>Height of display shall not exceed 3 m (top of display to surrounding grade)</p> <p>Message is restricted to the name of the community and/or an approved municipal logo or slogan.</p> <p>Width/length restricted to 6 m.</p>	<p>Locate near county boundary on county-maintained roads.</p> <p>Locate at intersection of county boundary and county-maintained roadways with high [>5000 veh/day] traffic volumes.</p>	<p>"Boundary Signs are installed, as close as practicable, to where the limits of the municipality cross the roadway." (page 128)</p> <p>"Two signs shall be installed, one for each direction of travel on the roadway." (page 128)</p> <p>"Where boundaries overlap, they are to be signed individually in the following order, as applicable: 1) Upper-tier, single-tier municipalities or First Nations Territories; 2) Lower-tier municipalities; 3) Formerly incorporated municipalities or hamlets." (page 128)</p> <p>"To be eligible for a Boundary Sign: 1) The freeway shall pass through a community; 2) The freeway forms part of a community's boundary; 3) There shall be one or more freeway interchanges servicing the community." (page 72)</p> <p>"When two or more municipalities, formerly incorporated municipalities or First Nations communities abut the freeway on either side, and when the freeway forms part of the boundary, the abutting communities do not qualify for a Boundary Sign. Instead, consideration should be given to provide Destination Signs at one interchange, typically the one serving their main population centre." (page 72)</p> <p>Note: Full definition of freeway and non-freeway facilities can be found in the OTM, Book 8, Volume 1, page 3.</p>
COUNTY GATEWAY SIGN - SECONDARY	These signs identify Middlesex and supplement the Primary Gateway Signs.	Same criteria as G-T1-#, see above.	Locate at intersection of county boundary and paved county-maintained roadways with medium [2500-5000 veh/day] traffic volumes.	Same criteria as G-T1-#, see above.
LOWER TIER MUNICIPAL GATEWAY SIGN	<p>Displays unique Municipal identity as well as Middlesex County identifier.</p> <p>(Municipality of Adelaide Metcalfe, Municipality of Lucan Biddulph, Municipality of Middlesex Centre, Municipality of North Middlesex, Municipality of Southwest Middlesex, Municipality of Strathroy-Caradoc, Municipality of Thames Centre, Village of Newbury)</p>	Same criteria as G-T1-#, see above.	Locate at intersection of municipal boundary and county-maintained roadways with highest traffic volume and/or which are used as a themed route.	Same criteria as G-T1-#, see above.
COMMUNITY GATEWAY SIGN	<p>Welcomes incoming traffic to township.</p> <p>Optional buy-in for each community. Recommended that existing signs are replaced at end of life span.</p>	Same criteria as G-T1-#, see above.	Locate at intersection of township boundary and county-maintained roadway with highest traffic count or which services economic/political centre of community .	Same criteria as G-T1-#, see above.

Type	Description	Design Criteria	Form:Media Recommendations	*Relevant Guidelines from the Ontario Traffic Manual (OTM), Book 8, Volume 1
ROUTE INTRODUCTION	<p>These signs are located at major entry points to the Grassroutes and display a simple route map.</p> <p>Displays Middlesex County identifier.</p> <p>If located at a major decision point, an arrow indicates the direction to the Grassroutes.</p>		<p>Locate at major route entrance.</p> <p>Locate at/near intersection of routes and county-maintained roadways with high [>5000 veh/day] traffic volumes.</p> <p>Locate at/near off-ramps of interchanges on provincial freeways (401,402) that: 1) abut county-maintained roadways with high [>5000 veh/day] traffic volumes; 2) service an area that is near themed route.</p>	<p>"On single-lane ramps that end in a simple, STOP-controlled "T" intersection, a standalone sign(s) or sign assemblies should be placed opposite the stem of the "T". For this situation, the crossing roadway is generally identified as follows: 1) Where the crossing roadway is a provincial route, a Route Marker Assembly should be installed; 2) Where the crossing roadway is a non-provincial route, a Low-Speed Roadway Identification Sign should be installed." (page 95)</p> <p>"Roadways, destinations and services may be identified on provincial freeway off-ramps, except at freeway-to-freeway connections." (93)</p>
ROUTE ASSURANCE/ID MARKERS	<p>Display route name and icon on roadside sign markers along themed routes.</p>		<p>Locate at 15-20 km intervals along themed route.</p>	<p>"Route Markers and Marker Tabs identify the intersection of numbered crossing roadways. They are placed immediately beyond an intersection or interchange." (page 24)</p> <p>"Auxiliary Assurance Signs should be installed at 20 km intervals along routes through remote areas where the distance between qualifying communities is 50 km or greater." (page 135)</p> <p>"Markers are generally used on each approach, one in advance and one at the intersection." (page 26)</p>
ROUTE DIRECTIONAL MARKER	<p>Display route name and icon with a directional arrow at major decision points.</p>		<p>Locate at major decision points along themed route.</p> <p>Follow guidelines for Highway Intersection Signs in the OTM Book 8 Vol.1</p>	<p>Refer to Table 8.1 and 8.2 in the OTM, Book 8, Vol.1, page 105-6.</p>
MUNICIPAL AMENITY IDENTIFICATION	<p>Identify municipal buildings and amenities.</p>		<p>Locate at public buildings, facilities, and spaces.</p>	<p>Refer to Appendix B of the County of Middlesex Tourism Signage Policy for definitive listing.</p>
PARKING IDENTIFICATION	<p>Identify major public parking areas in downtown areas.</p>		<p>Locate at major public parking lots in downtown areas.</p>	
HERITAGE RIVER IDENTIFICATION	<p>Identify natural heritage features, specifically rivers.</p>	<p>Only those features with approved names may be considered for signs.</p> <p>Words such as 'River' and 'Lake' may be abbreviated to 'R.' and 'L.' where appropriate.</p>	<p>Locate at primary stopping area for geographic feature.</p> <p>Where roadway physically crosses a feature or is adjacent to it, locate sign at the feature for each direction of travel.</p>	<p>Refer to OTM, Book 8, Vol. 1, page 87.</p>
INFORMATION KIOSK - VEHICULAR	<p>Display orientation maps and directional information as well as details about local attractions/amenities for the immediate area or community.</p>		<p>Locate near primary points of entry into the County.</p> <p>Stopping points or rest areas should be created as necessary to accommodate these units.</p> <p>Locate at stopping points/rest areas on county-maintained roads with high [>5000 veh/day] traffic volumes.</p> <p>Locate at stopping points/rest areas near interchanges on provincial freeways (401,402) that: 1) abut county-maintained roadways with high [>5000 veh/day] traffic volumes; 2) service an area that is near themed route.</p>	
INFORMATION KIOSK - PEDESTRIAN	<p>Displays orientation maps and related information. Smaller than vehicular kiosks.</p>		<p>Locate in high pedestrian foot-traffic areas; (e.g., downtown business districts).</p> <p>Locate according to local by-laws.</p>	<p>Refer to County of Middlesex Tourism Signage Policy Section 2.5 and Appendices A and B</p>

Type	Description	Design Criteria	Form:Media Recommendations	*Relevant Guidelines from the Ontario Traffic Manual (OTM), Book 8, Volume 1
INTERPRETIVE PANELS	Displays historic/narrative information.		Locate at sites deemed significant by Middlesex County; (e.g., Heritage Trail stopping points).	
INTERPRETIVE MARKERS	Simple visual markers for specific points of interest.		Locate at pedestrian accessible areas for points of interest; (e.g., barn quilt locations). Locate according to local by-laws.	Refer to County of Middlesex Tourism Signage Policy and Appendices A and B Section 2.5
SERVICE CLUB SIGNS	Informs visitors of local branches of service clubs within a community.	Upper panel – community name and slogan/welcome message. Lower panel(s) – 1, 2 or 3 rows of service clubs. Each row displays a max. of 4 clubs. Each service club board shall be a maximum of 600 mm x 600 mm in size, however they do not need to be square.	Locate a minimum of 100m downstream from Community Gateway Sign (G-T4-#). Locate according to local by-laws.	Refer to OTM, Book 8, Vol. 1, page 185-7. "Service Club Composite Boards should be installed beyond the right shoulder, near the municipal boundary or at the edge of the built-up area." (page 186) "A maximum of nine service clubs logos may appear on a single sign. Signs may be configured to display three, six or nine logos, as necessary. When there are more than nine qualifying clubs in a community, a second Service Club Composite Board may be installed approximately 100 m downstream from the first." (page 186) Refer to County of Middlesex Business Signage Policy
PUBLIC DESTINATION DIRECTIONAL	Provide directions to public county-wide attractions/amenities.		Locate on routes in advance of from attractions/amenities. Locate at major decision points along route in district where the attraction/amenity is located. In the case that the attraction/amenity is located off established routes, locate upstream from intersection that connects attraction/amenity to route. Locate according to local by-laws.	Refer to County of Middlesex Tourism Signage Policy and Appendices A and B Section 2.5 "Guide and Information Signs [...] are located in advance, at or departing an intersection or interchange." (page 23) "Destinations selected to be displayed on directional signs are chosen based on their likelihood of being a destination for a proportion of road users, combined with the availability of essential motorist services." (page 27) "Destination information may be provided: 1) At, or approaching, intersections and interchanges; 2) Beyond intersections and interchanges, to provide assurance of route choice; 3) Between widely spaced intersections in remote areas, to provide auxiliary assurance of route choice, and the likely availability of essential motorist services." (page 27)
PEDESTRIAN DIRECTIONAL	Direct pedestrians to public points of interest in downtown areas.		Locate in high pedestrian foot-traffic areas; (e.g., downtown business districts). Locate according to local by-laws.	
PARKING DIRECTIONAL	Direct traffic to parking areas in downtown cores.		Locate along primary roadway in township directing to parking. Locate at major decision points along route.	
PAY-TO-PLAY DIRECTIONAL SIGNAGE - MULTIPLE	Directional information for multiple private vendors/attractions.		Locate at major decision points on county-maintained roadways near private vendor/attraction locations. Locate at county-maintained intersections where a high volume of potential vendors/attractions exists. Locate according to local by-laws.	Refer to County of Middlesex Business Signage Policy
PAY-TO-PLAY DIRECTIONAL SIGNAGE - SINGLE	Directional information for a single private vendor/attraction.		Locate at major decision point on county-maintained roadway near private vendor/attraction location. Locate according to local by-laws.	Refer to County of Middlesex Business Signage Policy



Gateway Signage

COUNTY GATEWAY SIGN – PRIMARY

These signs welcome visitors to the County of Middlesex and distinctly identify the County. They are positioned near County boundaries on County-maintained roads of high traffic volumes or used as the tourism route.

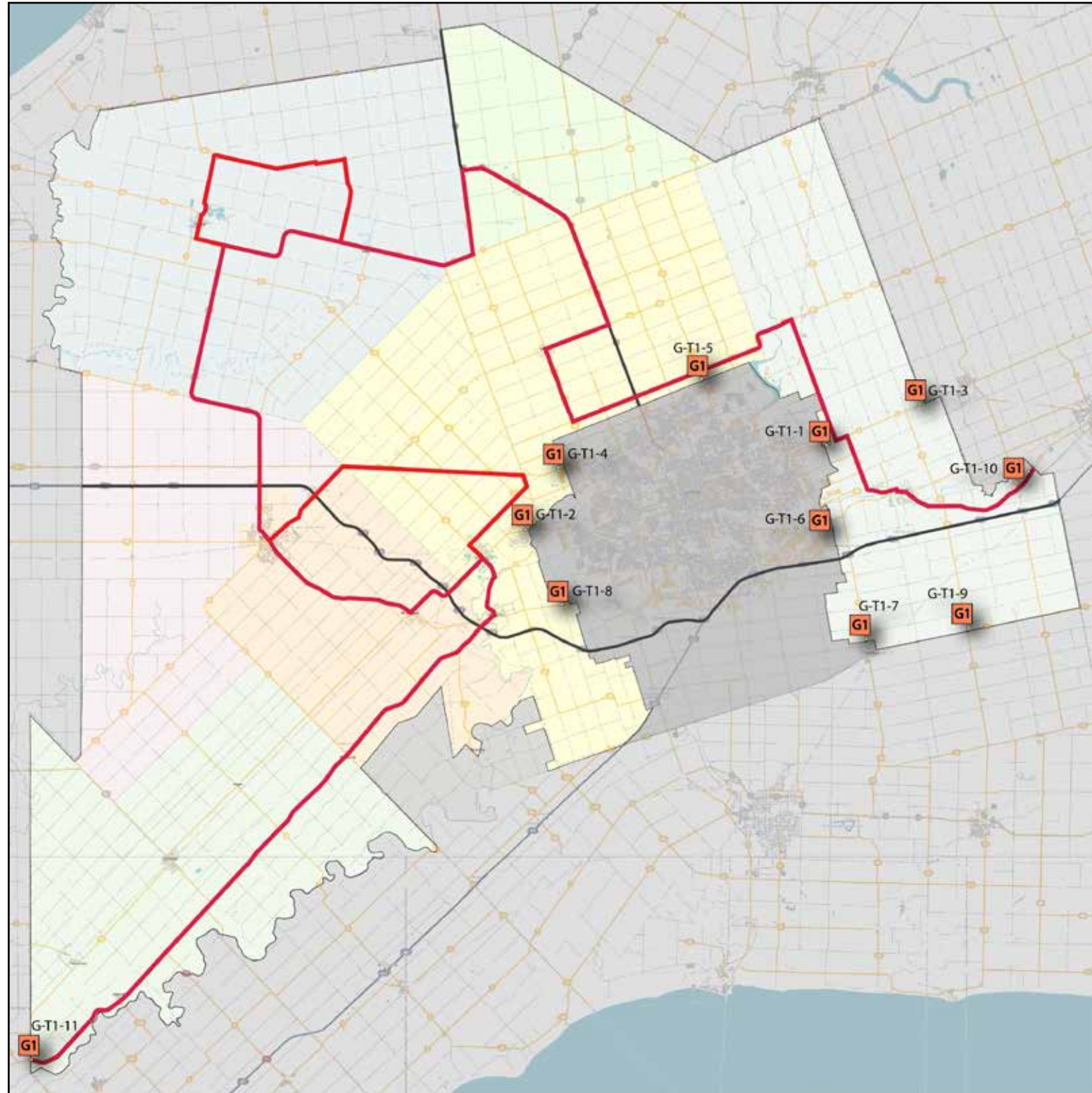

NOTE: All sign placement recommendations within this document are intended to be approximate only. Prior to installation, all sign locations shall be reviewed and adjusted as needed by the client's sign production team to meet all applicable guidelines and bylaws for each location. Site verification by the client is required for final locations of signs. Form:Media will not be responsible for finalizing any locations.

Sign Information		Site Information				Approx. Location		Phase			Total Cost
Sign ID	Primary Messaging	Existing Sign	Traffic Volume	Speed Limit	Required Spacing	Latitude	Longitude	PHASE 1 2014-2015	PHASE 2 2015-2018	PHASE 3 2019 +	
G-T1-1	COUNTY OF MIDDLESEX	no	15382 veh/day	80 km/hr	75 m	43.0186068	-81.12675522	\$ 6,000.00			\$ 6,000.00
G-T1-2	COUNTY OF MIDDLESEX	no	12454 veh/day	80 km/hr	75 m	42.96351422	-81.3915954	\$ 6,000.00			\$ 6,000.00
G-T1-3	COUNTY OF MIDDLESEX	yes	12558 veh/day	80 km/hr	75 m	43.04495643	-81.04157417	\$ 6,000.00			\$ 6,000.00
G-T1-4	COUNTY OF MIDDLESEX	no	9757 veh/day	80 km/hr	75 m	43.00426754	-81.359629	\$ 6,000.00			\$ 6,000.00
G-T1-5	COUNTY OF MIDDLESEX	no	9337 veh/day	80 km/hr	75 m	43.06104559	-81.23620612	\$ 6,000.00			\$ 6,000.00
G-T1-6	COUNTY OF MIDDLESEX	no	7909 veh/day	80 km/hr	75 m	42.96933781	-81.12057678	\$ 6,000.00			\$ 6,000.00
G-T1-7	COUNTY OF MIDDLESEX	yes	7013 veh/day	50 km/hr	NA	42.89072655	-81.08972662	\$ 6,000.00			\$ 6,000.00
G-T1-8	COUNTY OF MIDDLESEX	no	6170 veh/day	80 km/hr	75 m	42.91458768	-81.3603972	\$ 6,000.00			\$ 6,000.00
G-T1-9	COUNTY OF MIDDLESEX	yes	6126 veh/day	90 km/hr	100 m	42.8992985	-80.99970257	\$ 6,000.00			\$ 6,000.00
G-T1-10	COUNTY OF MIDDLESEX	yes	4388 veh/day	80 km/hr	75 m	43.00314449	-80.94058373	\$ 6,000.00			\$ 6,000.00
G-T1-11	COUNTY OF MIDDLESEX	yes	2052 veh/day	80 km/hr	75 m	42.6167415	-81.83482088	\$ 6,000.00			\$ 6,000.00
TOTAL NUMBER								11	0	0	11
TOTAL COST								\$ 66,000.00	\$ -	\$ -	\$ 66,000.00

NOTE: All final messaging shall be reviewed and finalized by the County prior to fabrication. The document is for preliminary message development only.



Gateway Signage

COUNTY GATEWAY SIGN – SECONDARY

Positioned at secondary points of entry (i.e. on arterial county-maintained roadways into the County) these signs identify Middlesex and supplement the Primary Gateway Signs.

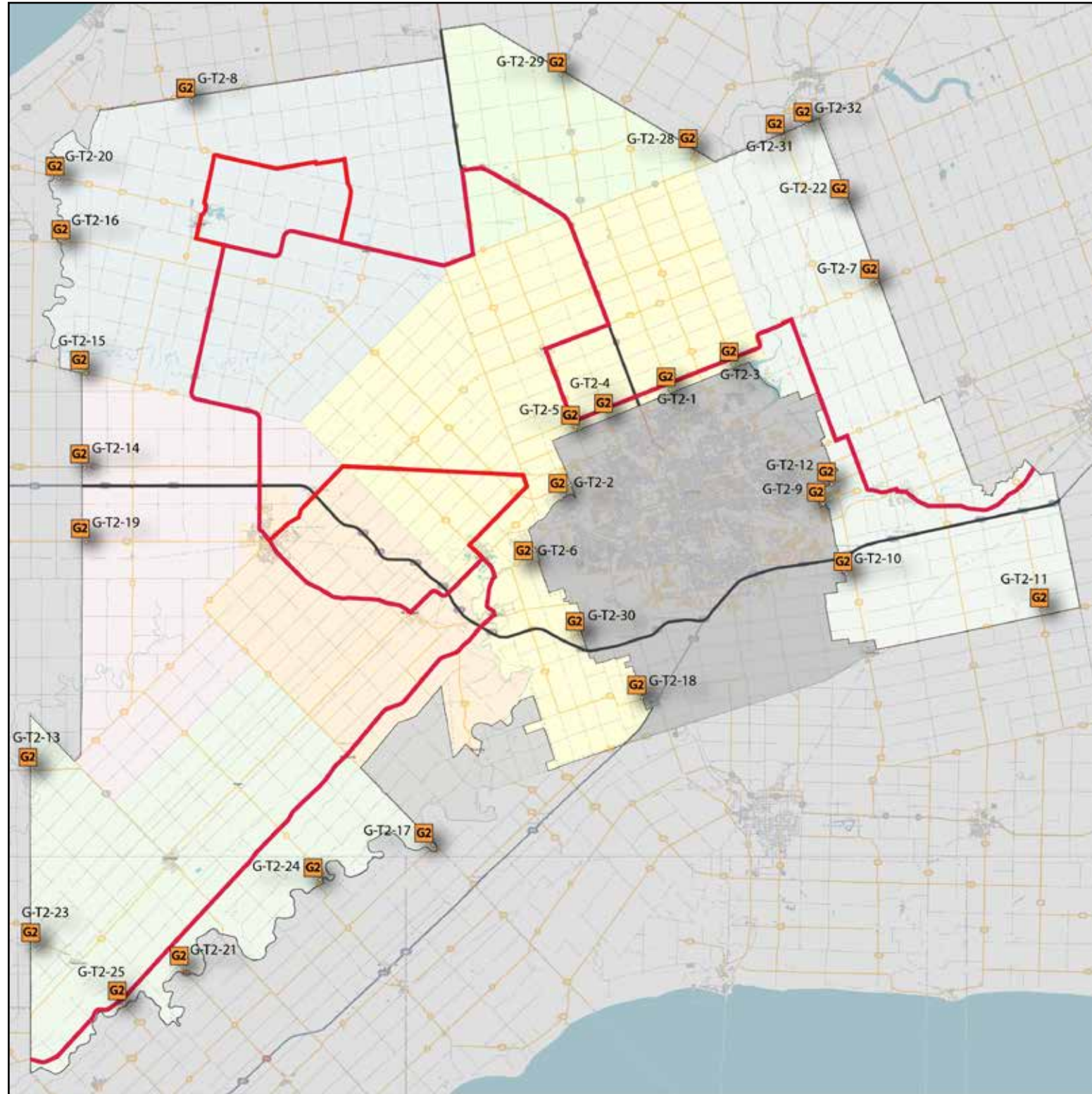

NOTE: All sign placement recommendations within this document are intended to be approximate only. Prior to installation, all sign locations shall be reviewed and adjusted as needed by the client's sign production team to meet all applicable guidelines and bylaws for each location. Site verification by the client is required for final locations of signs. Form:Media will not be responsible for finalizing any locations.

Sign Information		Site Information				Approx. Location		Phase			Total Cost
Sign ID	Primary Messaging	Existing Sign	Traffic Volume	Speed Limit	Required Spacing	Latitude	Longitude	PHASE 1 2014-2015	PHASE 2 2015-2018	PHASE 3 2019 +	
G-T2-1	COUNTY OF MIDDLESEX	no	5492 veh/day	80 km/hr	75 m	43.05336964	-81.26472506	\$ 1,900.00			\$ 1,900.00
G-T2-2	COUNTY OF MIDDLESEX	no	4690 veh/day	80 km/hr	75 m	42.99282873	-81.35294638	\$ 1,900.00			\$ 1,900.00
G-T2-3	COUNTY OF MIDDLESEX	no	4618 veh/day	80 km/hr	75 m	43.0704519	-81.20895185	\$ 1,900.00			\$ 1,900.00
G-T2-4	COUNTY OF MIDDLESEX	no	4551 veh/day	80 km/hr	75 m	43.03631862	-81.31967385	\$ 1,900.00			\$ 1,900.00
G-T2-5	COUNTY OF MIDDLESEX	no	4527 veh/day	80 km/hr	75 m	43.02813509	-81.3477964	\$ 1,900.00			\$ 1,900.00
G-T2-6	COUNTY OF MIDDLESEX	no	4357 veh/day	80 km/hr	75 m	42.95165188	-81.38452838	\$ 1,900.00			\$ 1,900.00
G-T2-7	COUNTY OF MIDDLESEX	yes	4102 veh/day	80 km/hr	75 m	43.12447717	-81.07839383	\$ 1,900.00			\$ 1,900.00
G-T2-8	COUNTY OF MIDDLESEX	no	3780 veh/day	90 km/hr	100 m	43.24158355	-81.69051849	\$ 1,900.00			\$ 1,900.00
G-T2-9	COUNTY OF MIDDLESEX	no	3639 veh/day	80 km/hr	75 m	42.97913223	-81.13041271	\$ 1,900.00			\$ 1,900.00
G-T2-10	COUNTY OF MIDDLESEX	no	3288 veh/day	80 km/hr	75 m	42.93528528	-81.107846	\$ 1,900.00			\$ 1,900.00
G-T2-11	COUNTY OF MIDDLESEX	yes	3106 veh/day	50 km/hr	NA	42.91019558	-80.93359203	\$ 1,900.00			\$ 1,900.00
G-T2-12	COUNTY OF MIDDLESEX	no	3087 veh/day	80 km/hr	75 m	42.99280672	-81.12163635	\$ 1,900.00			\$ 1,900.00
G-T2-13	COUNTY OF MIDDLESEX	yes	2064 veh/day	90 km/hr	100 m	42.80632859	-81.83489313	\$ 1,900.00			\$ 1,900.00
G-T2-14	COUNTY OF MIDDLESEX	yes	2025 veh/day	90 km/hr	100 m	43.00433614	-81.78858457	\$ 1,900.00			\$ 1,900.00
G-T2-15	COUNTY OF MIDDLESEX	yes	1964 veh/day	90 km/hr	100 m	43.06560941	-81.78843504	\$ 1,900.00			\$ 1,900.00
G-T2-16	COUNTY OF MIDDLESEX	no	1899 veh/day	90 km/hr	100 m	43.15116501	-81.8071736	\$ 1,900.00			\$ 1,900.00
G-T2-17	COUNTY OF MIDDLESEX	yes	1857 veh/day	80 km/hr	75 m	42.75524049	-81.47399966	\$ 1,900.00			\$ 1,900.00
G-T2-18	COUNTY OF MIDDLESEX	no	1939 veh/day	80 km/hr	75 m	42.85329915	-81.28878879	\$ 1,900.00			\$ 1,900.00
G-T2-19	COUNTY OF MIDDLESEX	yes	1813 veh/day	80 km/hr	75 m	42.95578284	-81.78793624	\$ 1,900.00			\$ 1,900.00
G-T2-20	COUNTY OF MIDDLESEX	yes	1446 veh/day	90 km/hr	100 m	43.19297937	-81.81200135	\$ 1,900.00			\$ 1,900.00
G-T2-21	COUNTY OF MIDDLESEX	yes	1384 veh/day	80 km/hr	75 m	42.67584605	-81.6979311	\$ 1,900.00			\$ 1,900.00
G-T2-22	COUNTY OF MIDDLESEX	yes	947 veh/day *2009 due to construction	80 km/hr	75 m	43.17654249	-81.10518616	\$ 1,900.00			\$ 1,900.00
G-T2-23	COUNTY OF MIDDLESEX	no	924 veh/day	80 km/hr	75 m	42.69261352	-81.83172515	\$ 1,900.00			\$ 1,900.00
G-T2-24	COUNTY OF MIDDLESEX	yes	879 veh/day	80 km/hr	75 m	42.73324822	-81.57809666	\$ 1,900.00			\$ 1,900.00
G-T2-25	COUNTY OF MIDDLESEX	yes	n/a veh/day	50 km/hr	NA	42.65265145	-81.75169607	\$ 1,900.00			\$ 1,900.00
G-T2-28	COUNTY OF MIDDLESEX	no	1552 veh/day	80 km/hr	75 m	43.21105107	-81.2440251	\$ 1,900.00			\$ 1,900.00
G-T2-29	COUNTY OF MIDDLESEX	yes	n/a veh/day	80 km/hr	75 m	43.26053778	-81.36091779	\$ 1,900.00			\$ 1,900.00

NOTE: All final messaging shall be reviewed and finalized by the County prior to fabrication. The document is for preliminary message development only.

Sign Information		Site Information				Approx. Location		Phase			Total Cost
Sign ID	Primary Messaging	Existing Sign	Traffic Volume	Speed Limit	Required Spacing	Latitude	Longitude	PHASE 1 2014-2015	PHASE 2 2015-2018	PHASE 3 2019 +	
G-T2-30	COUNTY OF MIDDLESEX	no	n/a veh/day	80 km/hr	75 m	42.89557343	-81.34297565	\$ 1,900.00			\$ 1,900.00
G-T2-31	COUNTY OF MIDDLESEX	yes	3009 veh/day	80 km/hr	75 m	43.22071463	-81.16322964	\$ 1,900.00			\$ 1,900.00
G-T2-32	COUNTY OF MIDDLESEX	no	n/a veh/day	80 km/hr	75 m	43.22854553	-81.14183071	\$ 1,900.00			\$ 1,900.00
TOTAL NUMBER								30	0	0	
TOTAL COST \$								\$ 57,000.00	\$ -	\$ -	\$ 57,000.00

NOTE: All final messaging shall be reviewed and finalized by the County prior to fabrication. The document is for preliminary message development only.

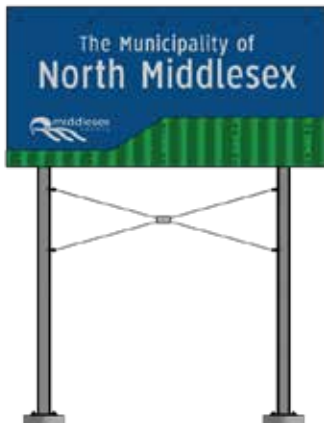

Gateway Signage

LOWER TIER MUNICIPAL GATEWAY SIGN

These signs allow lower tier Municipalities to uniquely identify themselves on direct entry routes within their respective Municipal boundaries. Middlesex County will also be identified on these sign types.

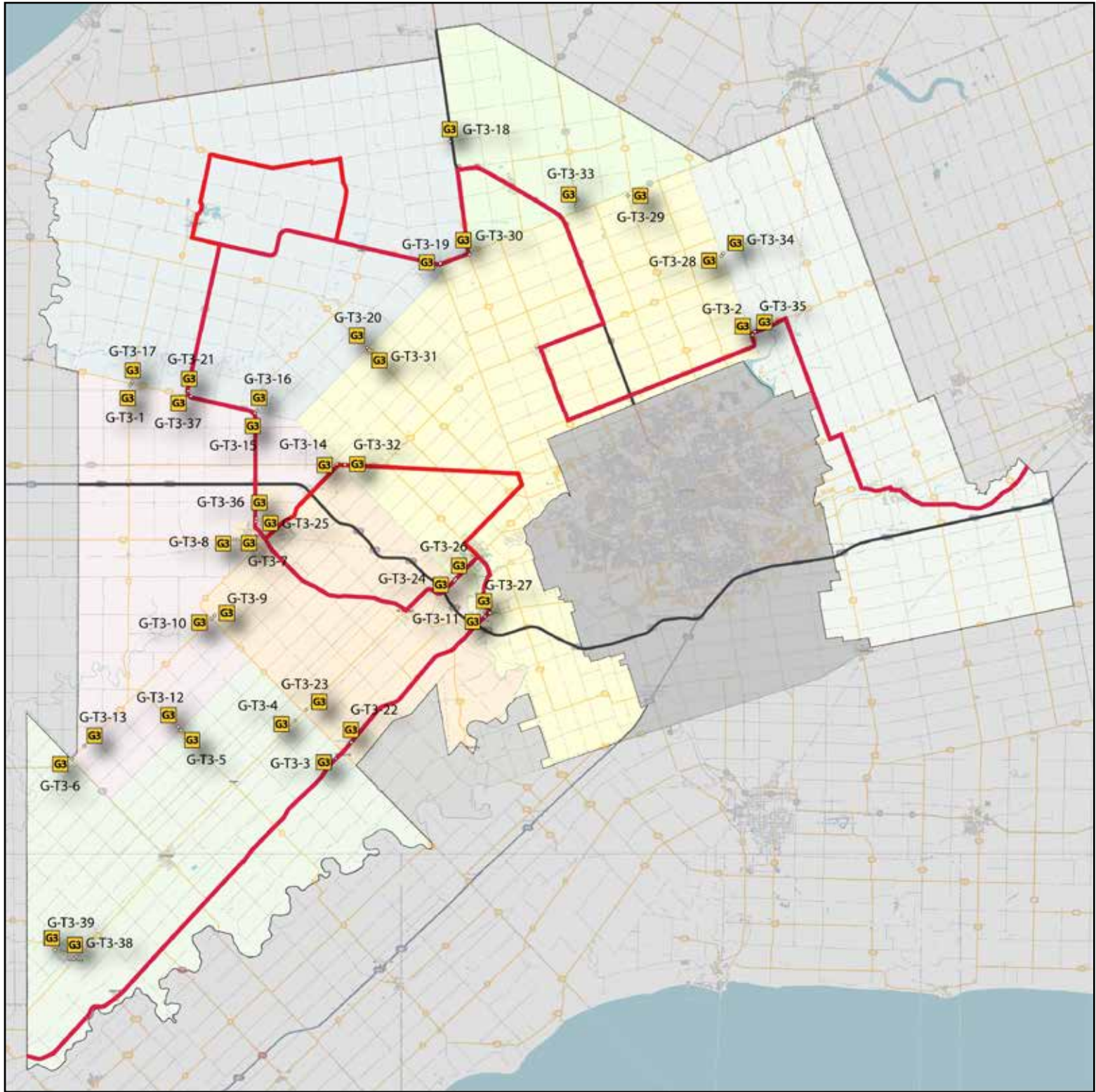

NOTE: All sign placement recommendations within this document are intended to be approximate only. Prior to installation, all sign locations shall be reviewed and adjusted as needed by the client’s sign production team to meet all applicable guidelines and bylaws for each location. Site verification by the client is required for final locations of signs. Form:Media will not be responsible for finalizing any locations.

Sign Information		Site Information				Approx. Location		Phase			Total Cost
Sign ID	Primary Messaging	Existing Sign	Traffic Volume	Speed Limit	Required Spacing	Latitude	Longitude	PHASE 1 2014-2015	PHASE 2 2015-2018	PHASE 3 2019 +	
G-T3-1	The Township of Adelaide Metcalfe	no	NA veh/day	90 km/hr	100 m	43.05662508	-81.74315027			\$ 2,400.00	\$ 2,400.00
G-T3-2	The Municipality of Middlesex Centre - You're in the Right Place! A Middlesex County Community	yes	5497 veh/day	80 km/hr	75 m	43.08957898	-81.18660615			\$ 2,400.00	\$ 2,400.00
G-T3-3	The Municipality of Southwest Middlesex...Someplace Special!	no	3083 veh/day	90 km/hr	100 m	42.81208335	-81.55916947			\$ 2,400.00	\$ 2,400.00
G-T3-4	The Municipality of Southwest Middlesex...Someplace Special!	yes	2083 veh/day	90 km/hr	100 m	42.83684711	-81.59572671			\$ 2,400.00	\$ 2,400.00
G-T3-5	The Municipality of Southwest Middlesex...Someplace Special!	yes	1062 veh/day	90 km/hr	100 m	42.83071289	-81.6976746			\$ 2,400.00	\$ 2,400.00
G-T3-6	The Municipality of Southwest Middlesex...Someplace Special!	yes	1237 veh/day	80 km/hr	75 m	42.81180861	-81.79532598			\$ 2,400.00	\$ 2,400.00
G-T3-7	The Municipality of Strathroy-Caradoc - Urban Opportunity - Rural Hospitality	no	1813 veh/day	60 km/hr	50 m	42.95550341	-81.64757835			\$ 2,400.00	\$ 2,400.00
G-T3-8	The Township of Adelaide Metcalfe	no	1813 veh/day	60 km/hr	50 m	42.95560941	-81.65028213			\$ 2,400.00	\$ 2,400.00
G-T3-9	The Municipality of Strathroy-Caradoc - Urban Opportunity - Rural Hospitality	no	1728 veh/day	80 km/hr	75 m	42.90577487	-81.66779761			\$ 2,400.00	\$ 2,400.00
G-T3-10	The Township of Adelaide Metcalfe	no	1728 veh/day	80 km/hr	75 m	42.90357494	-81.67072641			\$ 2,400.00	\$ 2,400.00
G-T3-11	The Municipality of Strathroy-Caradoc - Urban Opportunity - Rural Hospitality	no	6170 veh/day	60 km/hr	50 m	42.9050857	-81.42586042			\$ 2,400.00	\$ 2,400.00
G-T3-12	The Township of Adelaide Metcalfe	yes	1062 veh/day	90 km/hr	100 m	42.83282897	-81.70022351			\$ 2,400.00	\$ 2,400.00
G-T3-13	The Township of Adelaide Metcalfe	no	1237 veh/day	80 km/hr	75 m	42.82026565	-81.78441778			\$ 2,400.00	\$ 2,400.00
G-T3-14	The Township of Adelaide Metcalfe	yes	2882 veh/day	90 km/hr	100 m	43.00495812	-81.55838133			\$ 2,400.00	\$ 2,400.00
G-T3-15	The Township of Adelaide Metcalfe	no	2170 veh/day	90 km/hr	100 m	43.03833332	-81.63200847			\$ 2,400.00	\$ 2,400.00
G-T3-16	The Municipality of North Middlesex established 2001 population 6697: Proud Heritage - Bright Future - Working Together	yes	2789 veh/day	90 km/hr	100 m	43.03979552	-81.63003255			\$ 2,400.00	\$ 2,400.00
G-T3-17	The Municipality of North Middlesex established 2001 population 6697: Proud Heritage - Bright Future - Working Together	yes	NA veh/day	90 km/hr	100 m	43.058907	-81.7413668			\$ 2,400.00	\$ 2,400.00
G-T3-18	The Municipality of North Middlesex established 2001 population 6697: Proud Heritage - Bright Future - Working Together	no	852 veh/day	80 km/hr	75 m	43.21575514	-81.45718635			\$ 2,400.00	\$ 2,400.00

NOTE: All final messaging shall be reviewed and finalized by the County prior to fabrication. The document is for preliminary message development only.

Sign Information		Site Information				Approx. Location		Phase			Total Cost
Sign ID	Primary Messaging	Existing Sign	Traffic Volume	Speed Limit	Required Spacing	Latitude	Longitude	PHASE 1 2014-2015	PHASE 2 2015-2018	PHASE 3 2019 +	
G-T3-19	The Municipality of North Middlesex established 2001 population 6697: Proud Heritage - Bright Future - Working Together	no	4294 veh/day	90 km/hr	100 m	43.13617307	-81.46585932			\$ 2,400.00	\$ 2,400.00
G-T3-20	The Municipality of North Middlesex established 2001 population 6697: Proud Heritage - Bright Future - Working Together	yes	2481 veh/day	90 km/hr	100 m	43.08109818	-81.5313262			\$ 2,400.00	\$ 2,400.00
G-T3-21	The Municipality of North Middlesex established 2001 population 6697: Proud Heritage - Bright Future - Working Together	no	2170 veh/day	90 km/hr	100 m	43.05286037	-81.69137869			\$ 2,400.00	\$ 2,400.00
G-T3-22	The Municipality of Strathroy-Caradoc - Urban Opportunity - Rural Hospitality	no	3358 veh/day	90 km/hr	100 m	42.8225733	-81.54548243			\$ 2,400.00	\$ 2,400.00
G-T3-23	The Municipality of Strathroy-Caradoc - Urban Opportunity - Rural Hospitality	no	3099 veh/day	90 km/hr	100 m	42.84387449	-81.58595349			\$ 2,400.00	\$ 2,400.00
G-T3-24	The Municipality of Strathroy-Caradoc - Urban Opportunity - Rural Hospitality	no	6727 veh/day	80 km/hr	75 m	42.9286815	-81.45326499			\$ 2,400.00	\$ 2,400.00
G-T3-25	The Municipality of Strathroy-Caradoc - Urban Opportunity - Rural Hospitality	yes	9637 veh/day	50 km/hr	NA	42.96736223	-81.6309884			\$ 2,400.00	\$ 2,400.00
G-T3-26	The Municipality of Middlesex Centre - You're in the Right Place! A Middlesex County Community	yes	6727 veh/day	80 km/hr	75 m	42.92974054	-81.45178087			\$ 2,400.00	\$ 2,400.00
G-T3-27	The Municipality of Middlesex Centre - You're in the Right Place! A Middlesex County Community	yes	6170 veh/day	50 km/hr	NA	42.90754361	-81.42142878			\$ 2,400.00	\$ 2,400.00
G-T3-28	The Municipality of Middlesex Centre - You're in the Right Place! A Middlesex County Community	no	4597 veh/day	80km/hr	75 m	43.14099339	-81.2146914			\$ 2,400.00	\$ 2,400.00
G-T3-29	The Municipality of Middlesex Centre - You're in the Right Place! A Middlesex County Community	yes	7699 veh/day	90 km/hr	100 m	43.18044817	-81.29797468			\$ 2,400.00	\$ 2,400.00
G-T3-30	The Municipality of Middlesex Centre - You're in the Right Place! A Middlesex County Community	yes	NA veh/day	90 km/hr	100 m	43.14205218	-81.43977126			\$ 2,400.00	\$ 2,400.00
G-T3-31	The Municipality of Middlesex Centre - You're in the Right Place! A Middlesex County Community	yes	2481 veh/day	90 km/hr	100 m	43.07953146	-81.52956216			\$ 2,400.00	\$ 2,400.00

NOTE: All final messaging shall be reviewed and finalized by the County prior to fabrication. The document is for preliminary message development only.

Sign Information		Site Information				Approx. Location		Phase			Total Cost
Sign ID	Primary Messaging	Existing Sign	Traffic Volume	Speed Limit	Required Spacing	Latitude	Longitude	PHASE 1 2014-2015	PHASE 2 2015-2018	PHASE 3 2019 +	
G-T3-31	The Municipality of Middlesex Centre - You're in the Right Place! A Middlesex County Community	yes	2481 veh/day	90 km/hr	100 m	43.07953146	-81.52956216			\$ 2,400.00	\$ 2,400.00
G-T3-32	The Municipality of Middlesex Centre - You're in the Right Place! A Middlesex County Community	yes	7881 veh/day	90 km/hr	100 m	43.00459496	-81.55123515			\$ 2,400.00	\$ 2,400.00
G-T3-33	Welcome to the Township of Lucan Biddulph	no	NA veh/day	80 km/hr	75 m	43.17353441	-81.34377931			\$ 2,400.00	\$ 2,400.00
G-T3-34	The Municipality of Thames Centre A Middlesex County Community	no	4597 veh/day	80 km/hr	75 m	43.14270278	-81.21263333			\$ 2,400.00	\$ 2,400.00
G-T3-35	The Municipality of Thames Centre A Middlesex County Community	yes	5497 veh/day	70 km/hr	75 m	43.09164702	-81.18435308			\$ 2,400.00	\$ 2,400.00
G-T3-36	The Township of Adelaide Metcalfe	yes	9637 veh/day	50 km/hr	NA	42.96950175	-81.63073257			\$ 2,400.00	\$ 2,400.00
G-T3-37	The Township of Adelaide Metcalfe	yes	2170 veh/day	90 km/hr	100 m	43.04934715	-81.68896361			\$ 2,400.00	\$ 2,400.00
G-T3-38	The Village of Newbury - A Middlesex County Community	yes	1926 veh/day	50 km/hr	NA	42.680639	-81.791645			\$ 2,400.00	\$ 2,400.00
G-T3-39	The Village of Newbury - A Middlesex County Community	no	924 veh/day	80 km/hr	75 m	42.687901	-81.809476			\$ 2,400.00	\$ 2,400.00
TOTAL NUMBER								0	0	39	
TOTAL COST								\$ -	\$ -	\$ 93,600.00	\$ 93,600.00

NOTE: All final messaging shall be reviewed and finalized by the County prior to fabrication. The document is for preliminary message development only.



Themed Route Signage

ROUTE INTRODUCTION

These signs are located at major entry points to the Grassroutes and display a simple route map.

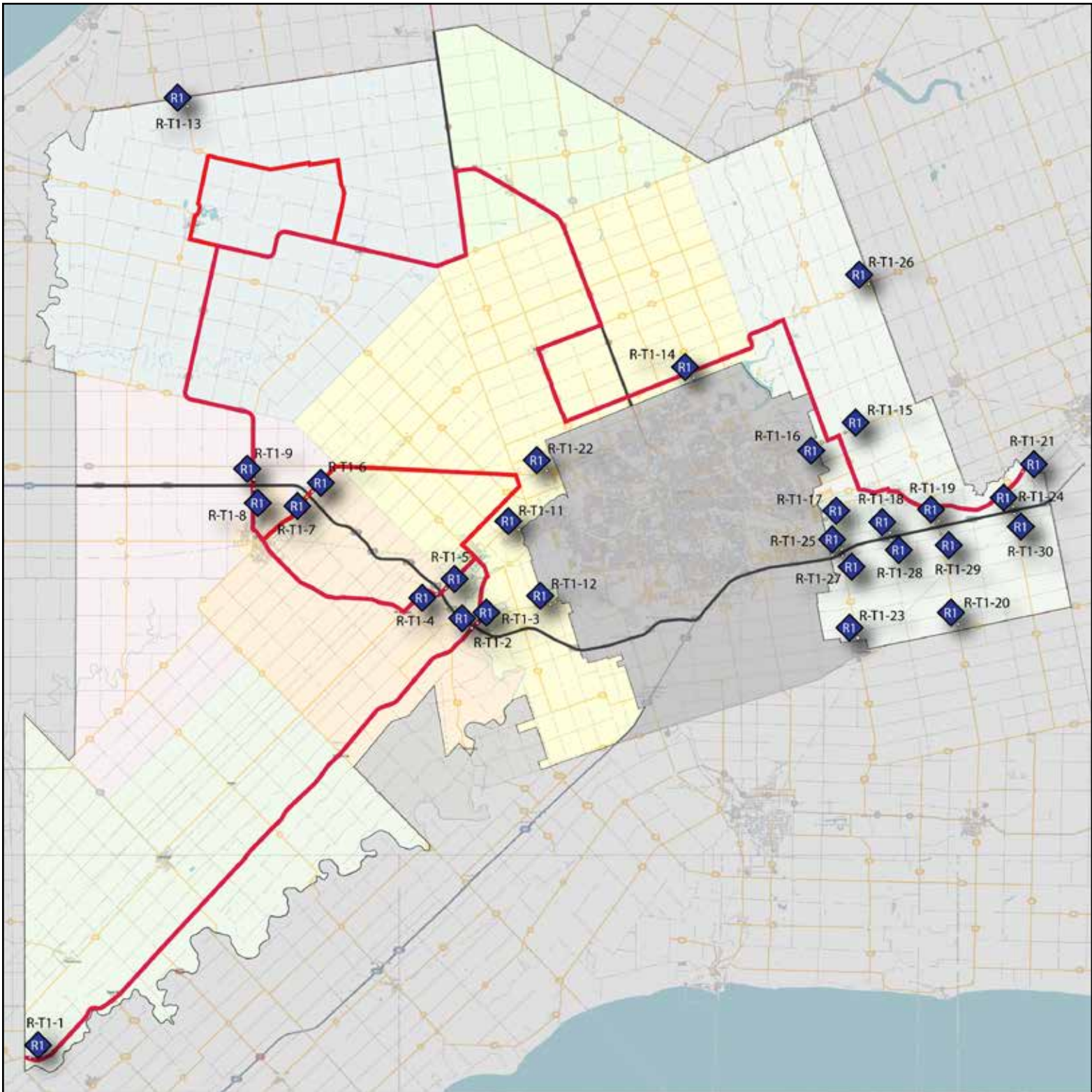

NOTE: All sign placement recommendations within this document are intended to be approximate only. Prior to installation, all sign locations shall be reviewed and adjusted as needed by the client's sign production team to meet all applicable guidelines and bylaws for each location. Site verification by the client is required for final locations of signs. Form:Media will not be responsible for finalizing any locations.

Sign Information		Site Information				Approx. Location		Phase			Total Cost	
Sign ID	Primary Messaging	Existing Sign	Traffic Volume	Speed Limit	Required Spacing	Latitude	Longitude	PHASE 1 2014-2015	PHASE 2 2015-2018	PHASE 3 2019 +		
R-T1-1	Explore the Grassroutes {with map graphic}	no	2052 veh/day	80 km/hr	75 m	42.61621817	-81.83114657		\$ 1,700.00		\$ 1,700.00	
R-T1-2	Explore the Grassroutes {with map graphic}	no	3358 veh/day	90 km/hr	100 m	42.89848406	-81.43557453		\$ 1,700.00		\$ 1,700.00	
R-T1-3	Explore the Grassroutes {with map graphic}	no	6170 veh/day	90 km/hr	100 m	42.90188763	-81.43054282		\$ 1,700.00		\$ 1,700.00	
R-T1-4	Explore the Grassroutes {with map graphic}	no	6727 veh/day	80 km/hr	75 m	42.92075049	-81.46686847		\$ 1,700.00		\$ 1,700.00	
R-T1-5	Explore the Grassroutes {with map graphic}	no	6727 veh/day	80 km/hr	75 m	42.9245925	-81.4586955		\$ 1,700.00		\$ 1,700.00	
R-T1-6	Explore the Grassroutes {with map graphic}	no	5497 veh/day	80 km/hr	75 m	42.98786601	-81.57833326		\$ 1,700.00		\$ 1,700.00	
R-T1-7	Explore the Grassroutes {with map graphic}	no	8519 veh/day	80 km/hr	75 m	42.98431669	-81.58346648		\$ 1,700.00		\$ 1,700.00	
R-T1-8	Explore the Grassroutes {with map graphic}	no	9637 veh/day	80 km/hr	75 m	42.98965022	-81.63076349		\$ 1,700.00		\$ 1,700.00	
R-T1-9	Explore the Grassroutes {with map graphic}	no	9637 veh/day	80 km/hr	75 m	42.99591029	-81.63058425		\$ 1,700.00		\$ 1,700.00	
R-T1-11	Explore the Grassroutes {with map graphic}	no	12454 veh/day	80 km/hr	75 m	42.96317795	-81.39344163		\$ 1,700.00		\$ 1,700.00	
R-T1-12	Explore the Grassroutes {with map graphic}	no	6170 veh/day	80 km/hr	75 m	42.91406274	-81.3653847		\$ 1,700.00		\$ 1,700.00	
R-T1-13	Explore the Grassroutes {with map graphic}	no	3780 veh/day	90 km/hr	100 m	43.23970395	-81.69010945		\$ 1,700.00		\$ 1,700.00	
R-T1-14	Explore the Grassroutes {with map graphic}	no	9337 veh/day	80 km/hr	75 m	43.06246097	-81.23696413		\$ 1,700.00		\$ 1,700.00	
R-T1-15	Explore the Grassroutes {with map graphic}	no	12558 veh/day	80km/hr	75 m	43.02658403	-81.10133929		\$ 1,700.00		\$ 1,700.00	
R-T1-16	Explore the Grassroutes {with map graphic}	no	15382 veh/day	80km/hr	75 m	43.01994177	-81.12210008		\$ 1,700.00		\$ 1,700.00	
R-T1-17	Explore the Grassroutes {with map graphic}	no	7909 veh/day	80 km/hr	75 m	42.96983588	-81.11883662		\$ 1,700.00		\$ 1,700.00	
R-T1-18	Explore the Grassroutes {with map graphic}	no	6126 veh/day	80 km/hr	75 m	42.96098716	-81.06132687		\$ 1,700.00		\$ 1,700.00	
R-T1-19	Explore the Grassroutes {with map graphic}	no	6126 veh/day	80 km/hr	75 m	42.96868128	-81.01748782		\$ 1,700.00		\$ 1,700.00	
R-T1-20	Explore the Grassroutes {with map graphic}	no	6126 veh/day	90 km/hr	100 m	42.90105237	-81.00016682		\$ 1,700.00		\$ 1,700.00	
R-T1-21	Explore the Grassroutes {with map graphic}	no	4388 veh/day	80 km/hr	75 m	43.0008865	-80.94239861		\$ 1,700.00		\$ 1,700.00	
R-T1-22	Explore the Grassroutes {with map graphic}	no	9757 veh/day	80 km/hr	75 m	43.00165621	-81.3686205		\$ 1,700.00		\$ 1,700.00	
R-T1-23	Explore the Grassroutes {with map graphic}	no	7013 veh/day	80 km/hr	75 m	42.8920546	-81.09002761		\$ 1,700.00		\$ 1,700.00	
R-T1-24	Explore the Grassroutes {with map graphic}	no	2582 veh/day	80 km/hr	75 m	42.97812073	-80.95094084		\$ 1,700.00		\$ 1,700.00	
R-T1-25	Explore the Grassroutes {with map graphic}	no	4556 veh/day	80 km/hr	75 m	42.95019488	-81.10451933		\$ 1,700.00		\$ 1,700.00	
R-T1-26	Explore the Grassroutes {with map graphic}	no	4102 veh/day	80 km/hr	75 m	43.12387832	-81.08021082		\$ 1,700.00		\$ 1,700.00	
R-T1-27	Explore the Grassroutes {with map graphic}	no	4556 veh/day	80 km/hr	75 m	42.94580909	-81.10368528		\$ 1,700.00		\$ 1,700.00	
R-T1-28	Explore the Grassroutes {with map graphic}	no	6126 veh/day	80 km/hr	75 m	42.95634227	-81.06041448		\$ 1,700.00		\$ 1,700.00	
R-T1-29	Explore the Grassroutes {with map graphic}	no	6126 veh/day	90 km/hr	100 m	42.96008849	-81.01548689		\$ 1,700.00		\$ 1,700.00	
R-T1-30	Explore the Grassroutes {with map graphic}	no	2582 veh/day	80 km/hr	75 m	42.97337814	-80.94997502		\$ 1,700.00		\$ 1,700.00	
TOTAL NUMBER								0	29	0		
TOTAL COST								\$	-	\$ 49,300.00	\$ -	\$ 49,300.00



Themed Route Signage

ROUTE ASSURANCE MARKERS

These signs provide route assurance by displaying the route name and route icon on roadside sign markers.

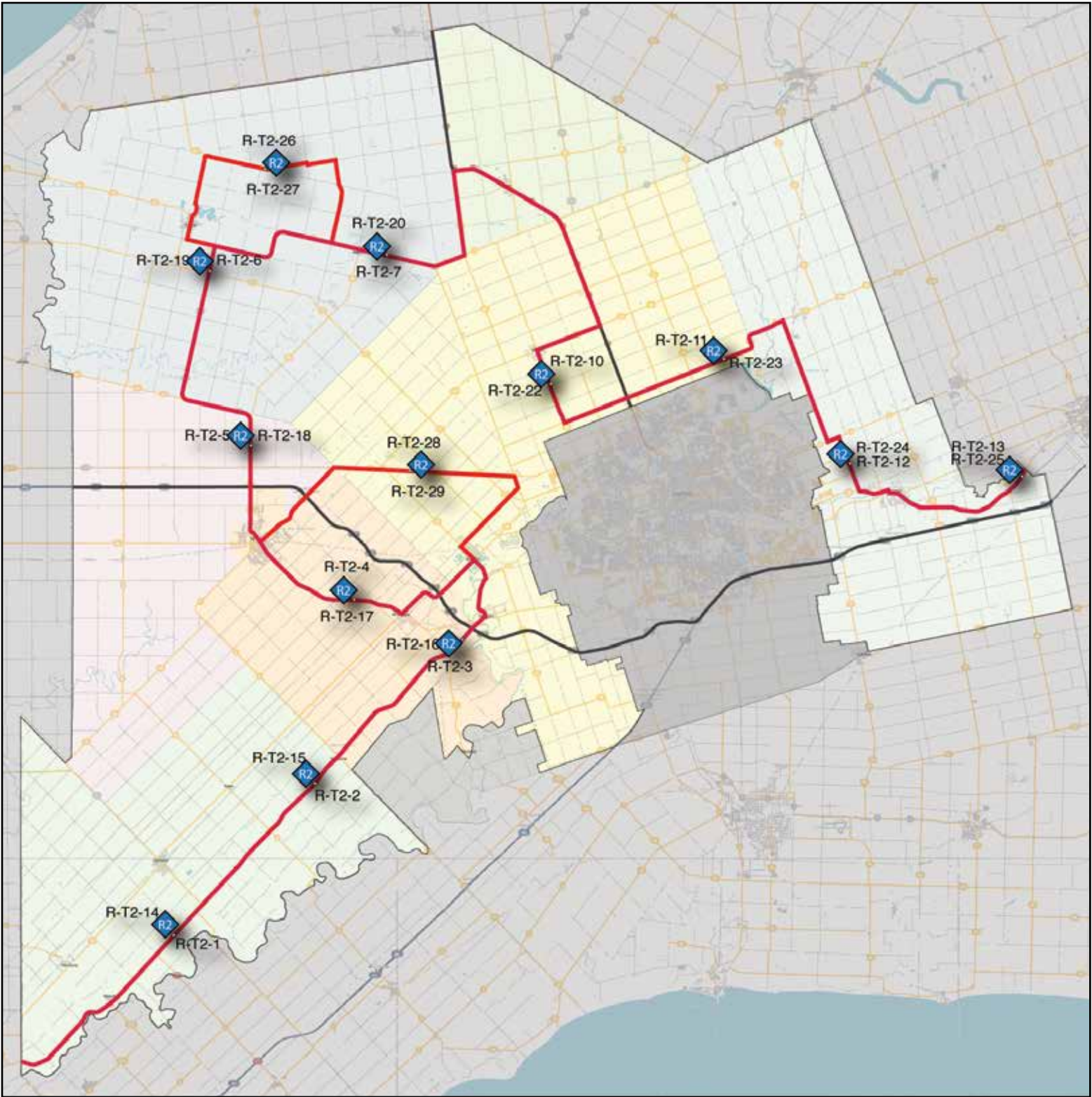

NOTE: All sign placement recommendations within this document are intended to be approximate only. Prior to installation, all sign locations shall be reviewed and adjusted as needed by the client's sign production team to meet all applicable guidelines and bylaws for each location. Site verification by the client is required for final locations of signs. Form:Media will not be responsible for finalizing any locations.

Sign Information		Site Information				Approx. Location		Phase			Total Cost
Sign ID	Primary Messaging	Existing Sign	Traffic Volume	Speed Limit	Required Spacing	Latitude	Longitude	PHASE 1 2014-2015	PHASE 2 2015-2018	PHASE 3 2019 +	
R-T2-1	{Route Icon}	no	NA	NA	NA	42.69904509	-81.69967044		\$ 900.00		\$ 900.00
R-T2-2	{Route Icon}	no	NA	NA	NA	42.79846769	-81.57373277		\$ 900.00		\$ 900.00
R-T2-3	{Route Icon}	no	NA	NA	NA	42.89232123	-81.44213709		\$ 900.00		\$ 900.00
R-T2-4	{Route Icon}	no	NA	NA	NA	42.91861562	-81.53888484		\$ 900.00		\$ 900.00
R-T2-5	{Route Icon}	no	NA	NA	NA	43.0190484	-81.63063804		\$ 900.00		\$ 900.00
R-T2-6	{Route Icon}	no	NA	NA	NA	43.13270191	-81.66736567		\$ 900.00		\$ 900.00
R-T2-7	{Route Icon}	no	NA	NA	NA	43.14296934	-81.50985619		\$ 900.00		\$ 900.00
R-T2-10	{Route Icon}	no	NA	NA	NA	43.05883936	-81.36384527		\$ 900.00		\$ 900.00
R-T2-11	{Route Icon}	no	NA	NA	NA	43.07523786	-81.20941799		\$ 900.00		\$ 900.00
R-T2-12	{Route Icon}	no	NA	NA	NA	43.00724913	-81.09738197		\$ 900.00		\$ 900.00
R-T2-13	{Route Icon}	no	NA	NA	NA	42.99890572	-80.9437765		\$ 900.00		\$ 900.00
R-T2-14	{Route Icon}	no	NA	NA	NA	42.69913052	-81.6998132		\$ 900.00		\$ 900.00
R-T2-15	{Route Icon}	no	NA	NA	NA	42.79855538	-81.57388531		\$ 900.00		\$ 900.00
R-T2-16	{Route Icon}	no	NA	NA	NA	42.89242466	-81.44234015		\$ 900.00		\$ 900.00
R-T2-17	{Route Icon}	no	NA	NA	NA	42.9185202	-81.53888915		\$ 900.00		\$ 900.00
R-T2-18	{Route Icon}	no	NA	NA	NA	43.0190479	-81.63086334		\$ 900.00		\$ 900.00
R-T2-19	{Route Icon}	no	NA	NA	NA	43.13272198	-81.6675047		\$ 900.00		\$ 900.00
R-T2-20	{Route Icon}	no	NA	NA	NA	43.14308245	-81.50983257		\$ 900.00		\$ 900.00
R-T2-22	{Route Icon}	no	NA	NA	NA	43.05887879	-81.36364388		\$ 900.00		\$ 900.00
R-T2-23	{Route Icon}	no	NA	NA	NA	43.07537222	-81.20950449		\$ 900.00		\$ 900.00
R-T2-24	{Route Icon}	no	NA	NA	NA	43.00732545	-81.09710568		\$ 900.00		\$ 900.00
R-T2-25	{Route Icon}	no	NA	NA	NA	42.99899187	-80.94397921		\$ 900.00		\$ 900.00
R-T2-26	{Route Icon}	no	NA	NA	NA	43.198462	-81.614123		\$ 900.00		\$ 900.00
R-T2-27	{Route Icon}	no	NA	NA	NA	43.198353	-81.614115		\$ 900.00		\$ 900.00
R-T2-28	{Route Icon}	no	NA	NA	NA	43.002732	-81.490941		\$ 900.00		\$ 900.00
R-T2-29	{Route Icon}	no	NA	NA	NA	43.002575	-81.49098		\$ 900.00		\$ 900.00
TOTAL NUMBER								0	26	0	
TOTAL COST								\$ -	\$ 23,400.00	\$ -	\$ 23,400.00

NOTE: All final messaging shall be reviewed and finalized by the County prior to fabrication. The document is for preliminary message development only.



Themed Route Signage

ROUTE DIRECTIONAL MARKER

Similar to the route assurance markers, these signs feature a directional arrow and will be positioned at major decision points.

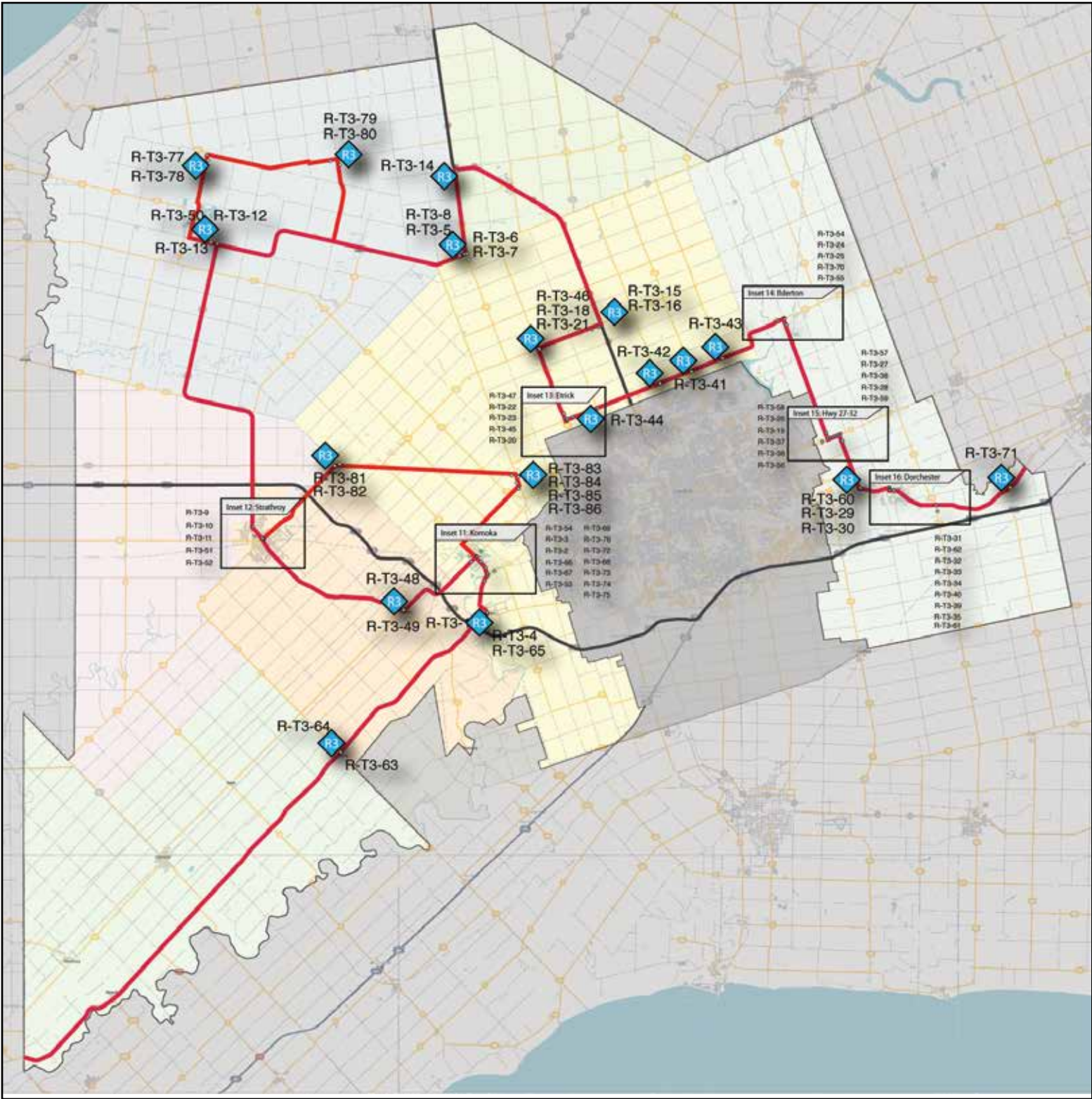

NOTE: All sign placement recommendations within this document are intended to be approximate only. Prior to installation, all sign locations shall be reviewed and adjusted as needed by the client's sign production team to meet all applicable guidelines and bylaws for each location. Site verification by the client is required for final locations of signs. Form:Media will not be responsible for finalizing any locations.



Sign Information		Site Information				Approx. Location		Phase			Total Cost
Sign ID	Primary Messaging	Existing Sign	Traffic Volume	Speed Limit	Required Spacing	Latitude	Longitude	PHASE 1 2014-2015	PHASE 2 2015-2018	PHASE 3 2019 +	
R-T3-1	← {Route Icon}	no	6170 veh/day	50 km/hr	NA	42.90750472	-81.42165593		\$ 900.00		\$ 900.00
R-T3-2	← {Route Icon}	no	3176 veh/day	80 km/hr	75 m	42.93255518	-81.42105751		\$ 900.00		\$ 900.00
R-T3-3	{Route Icon} →	no	3441 veh/day	80 km/hr	75 m	42.93372778	-81.42123042		\$ 900.00		\$ 900.00
R-T3-4	{Route Icon} →	no	3176 veh/day	50 km/hr	NA	42.9080113	-81.42141824		\$ 900.00		\$ 900.00
R-T3-5	{Route Icon} →	no	4294 veh/day	70 km/hr	75 m	43.14249941	-81.44198876		\$ 900.00		\$ 900.00
R-T3-6	← {Route Icon}	no	1692 veh/day	90 km/hr	100 m	43.14280851	-81.43988448		\$ 900.00		\$ 900.00
R-T3-7 ADVANCE	← {Route Icon}	no	1692 veh/day	90 km/hr	100 m	43.13874653	-81.43785606		\$ 900.00		\$ 900.00
R-T3-8 ADVANCE	{Route Icon} →	no	4294 veh/day	70 km/hr	75 m	43.14136741	-81.44612018		\$ 900.00		\$ 900.00
R-T3-9	← {Route Icon} →	no	8519 veh/day	50 km/hr	NA	42.95658584	-81.62140879		\$ 900.00		\$ 900.00
R-T3-10	↑ {Route Icon}	no	9637 veh/day	50 km/hr	NA	42.95666812	-81.6223024		\$ 900.00		\$ 900.00
R-T3-11	← {Route Icon}	no	9637 veh/day	50 km/hr	NA	42.96458115	-81.63096741		\$ 900.00		\$ 900.00
R-T3-12	{Route Icon} →	no	2170 veh/day	90 km/hr	100 m	43.14931052	-81.66248483		\$ 900.00		\$ 900.00
R-T3-13	↑ {Route Icon} →	no	2170 veh/day	90 km/hr	100 m	43.14917492	-81.66290286		\$ 900.00		\$ 900.00
R-T3-14	→ {Route Icon}	no	2575 veh/day	60 km/hr	50 m	43.0732371	-81.40362021		\$ 900.00		\$ 900.00
R-T3-15	{Route Icon} ←	no	4135 veh/day	90 km/hr	100 m	43.07310461	-81.40280722		\$ 900.00		\$ 900.00
R-T3-16 ADVANCE	{Route Icon} ←	no	4135 veh/day	90 km/hr	100 m	43.07476482	-81.39717253		\$ 900.00		\$ 900.00
R-T3-17	Sign Does Not Exist					43.07724386	-81.40579479		\$ 900.00		\$ 900.00
R-T3-18	Sign Does Not Exist					43.08092987	-81.37576019		\$ 900.00		\$ 900.00
R-T3-19 ADVANCE	← {Route Icon} ↑	no	15382 veh/day	80km/hr	75 m	43.02003701	-81.12199897		\$ 900.00		\$ 900.00
R-T3-20 ADVANCE	{Route Icon} →	no	4244 veh/day	80 km/hr	75 m	43.03607491	-81.34485684		\$ 900.00		\$ 900.00
R-T3-21	{Route Icon} →	no	4527 veh/day	50 km/hr	NA	43.08059262	-81.3749054		\$ 900.00		\$ 900.00
R-T3-22	← {Route Icon}	no	4527 veh/day	80 km/hr	75 m	43.03498377	-81.35130852		\$ 900.00		\$ 900.00
R-T3-23	{Route Icon} →	no	4244 veh/day	80 km/hr	75 m	43.03462455	-81.34987925		\$ 900.00		\$ 900.00
R-T3-24	{Route Icon} →	no	5497 veh/day	70 km/hr	75 m	43.10045133	-81.15670273		\$ 900.00		\$ 900.00
R-T3-25	← {Route Icon}	no	3532 veh/day	80 km/hr	75 m	43.1002726	-81.15590018		\$ 900.00		\$ 900.00
R-T3-26	← {Route Icon}	no	3532 veh/day	80 km/hr	75 m	43.02272823	-81.11688415		\$ 900.00		\$ 900.00

NOTE: All final messaging shall be reviewed and finalized by the County prior to fabrication. The document is for preliminary message development only.

Sign Information		Site Information				Approx. Location		Phase			Total Cost
Sign ID	Primary Messaging	Existing Sign	Traffic Volume	Speed Limit	Required Spacing	Latitude	Longitude	PHASE 1 2014-2015	PHASE 2 2015-2018	PHASE 3 2019 +	
R-T3-27	{Route Icon} →	no	15382 veh/day	80 km/hr	75 m	43.02408032	-81.10873709		\$ 900.00		\$ 900.00
R-T3-28	← {Route Icon}	no	15382 veh/day	80 km/hr	75 m	43.02414383	-81.10583788		\$ 900.00		\$ 900.00
R-T3-29	← {Route Icon}	no	3779 veh/day	50 km/hr	NA	42.99020405	-81.0884728		\$ 900.00		\$ 900.00
R-T3-30	{Route Icon} →	no	3779 veh/day	50 km/hr	NA	42.98968864	-81.08742746		\$ 900.00		\$ 900.00
R-T3-31	{Route Icon} →	no	3779 veh/day	50 km/hr	NA	42.99019741	-81.06285582		\$ 900.00		\$ 900.00
R-T3-32	← {Route Icon}	no	3779 veh/day	50 km/hr	NA	42.9900118	-81.06210561		\$ 900.00		\$ 900.00
R-T3-33	← {Route Icon}	no	3779 veh/day	50 km/hr	NA	42.98881893	-81.0616266		\$ 900.00		\$ 900.00
R-T3-34	{Route Icon} →	no	11632 veh/day	50 km/hr	NA	42.9886038	-81.06094686		\$ 900.00		\$ 900.00
R-T3-35	← {Route Icon} →	no	6126 veh/day	80 km/hr	75 m	42.97840188	-81.02004485		\$ 900.00		\$ 900.00
R-T3-36	{Route Icon} →	no	15382 veh/day	80 km/hr	75 m	43.02231862	-81.11529833		\$ 900.00		\$ 900.00
R-T3-37	← {Route Icon} ↑	no	15382 veh/day	80km/hr	75 m	43.02147738	-81.11714957		\$ 900.00		\$ 900.00
R-T3-38	← {Route Icon} ↑	no	12558 veh/day	80 km/hr	75 m	43.02531117	-81.10546681		\$ 900.00		\$ 900.00
R-T3-39	← {Route Icon} →	no	4050 veh/day	50 km/hr	NA m	42.98820206	-81.05831759		\$ 900.00		\$ 900.00
R-T3-40	← {Route Icon} ↑	no	5803 veh/day	50 km/hr	NA m	42.98839922	-81.06189671		\$ 900.00		\$ 900.00
R-T3-41	← {Route Icon} →	no	9337 veh/day	60 km/hr	50 m	43.06588922	-81.23888634		\$ 900.00		\$ 900.00
R-T3-42	← {Route Icon} →	no	5492 veh/day	80 km/hr	75 m	43.05802929	-81.26717579		\$ 900.00		\$ 900.00
R-T3-43	← {Route Icon} →	no	4618 veh/day	80 km/hr	75 m	43.0744026	-81.21104287		\$ 900.00		\$ 900.00
R-T3-44	← {Route Icon} →	no	4551 veh/day	80 km/hr	75 m	43.04193724	-81.32242537		\$ 900.00		\$ 900.00
R-T3-45	↑ {Route Icon} →	no	4527 veh/day	80 km/hr	75 m	43.03357132	-81.35033412		\$ 900.00		\$ 900.00
R-T3-46	← {Route Icon} →	no	4135 veh/day	50 km/hr	NA	43.08130597	-81.37483602		\$ 900.00		\$ 900.00
R-T3-47 ADVANCE	← {Route Icon}	no	4527 veh/day	80 km/hr	75 m	43.03858889	-81.35307447		\$ 900.00		\$ 900.00
R-T3-48	{Route Icon} →	no	6727 veh/day	50 km/hr	NA	42.91003128	-81.49537776		\$ 900.00		\$ 900.00
R-T3-49	← {Route Icon}	no	8809 veh/day	50 km/hr	NA	42.90986261	-81.4963336		\$ 900.00		\$ 900.00
R-T3-50 ADVANCE	↑ {Route Icon} →	no	2170 veh/day	90 km/hr	100 m	43.15012898	-81.66847136		\$ 900.00		\$ 900.00
R-T3-51	← {Route Icon} →	no	8519 veh/day	50 km/hr	NA	42.9559167	-81.62189372		\$ 900.00		\$ 900.00

NOTE: All final messaging shall be reviewed and finalized by the County prior to fabrication. The document is for preliminary message development only.

Sign Information		Site Information				Approx. Location		Phase			Total Cost
Sign ID	Primary Messaging	Existing Sign	Traffic Volume	Speed Limit	Required Spacing	Latitude	Longitude	PHASE 1 2014-2015	PHASE 2 2015-2018	PHASE 3 2019 +	
R-T3-52	↑ {Route Icon}	no	8809 veh/day	50 km/hr	NA	42.95604635	-81.62118118		\$ 900.00		\$ 900.00
R-T3-53 ADVANCE	← {Route Icon}	no	3176 veh/day	80 km/hr	75 m	42.9289004	-81.42383725		\$ 900.00		\$ 900.00
R-T3-54 ADVANCE	{Route Icon} →	no	5497 veh/day	70 km/hr	75 m	42.93781124	-81.42287023		\$ 900.00		\$ 900.00
R-T3-54 ADVANCE	{Route Icon} →	no	5497 veh/day	70 km/hr	75 m	43.09883753	-81.16191904		\$ 900.00		\$ 900.00
R-T3-55 ADVANCE	← {Route Icon}	no	3532 veh/day	80 km/hr	75 m	43.09632064	-81.15388708		\$ 900.00		\$ 900.00
R-T3-56 ADVANCE	{Route Icon} →	no	15382 veh/day	80 km/hr	75 m	43.02303766	-81.11213151		\$ 900.00		\$ 900.00
R-T3-57 ADVANCE	{Route Icon} →	no	15382 veh/day	80 km/hr	75 m	43.02383828	-81.11047049		\$ 900.00		\$ 900.00
R-T3-58	← {Route Icon}	no	3532 veh/day	80 km/hr	75 m	43.02595007	-81.11850954		\$ 900.00		\$ 900.00
R-T3-59 ADVANCE	← {Route Icon}	no	15382 veh/day	80 km/hr	75 m	43.02056181	-81.10395956		\$ 900.00		\$ 900.00
R-T3-60	← {Route Icon} ↑	no	3779 veh/day	50 km/hr	NA m	42.98965052	-81.08854758		\$ 900.00		\$ 900.00
R-T3-61 ADVANCE	← {Route Icon} →	no	6126 veh/day	80 km/hr	75 m	42.9745904	-81.01900048		\$ 900.00		\$ 900.00
R-T3-62	← {Route Icon} ↑	no	3779 veh/day	50 km/hr	NA	42.99057262	-81.06198607		\$ 900.00		\$ 900.00
R-T3-63	← {Route Icon} →	no	1857 veh/day	50 km/hr	NA	42.81655261	-81.55182372		\$ 900.00		\$ 900.00
R-T3-64	← {Route Icon} →	no	2079 veh/day	50 km/hr	NA	42.81693853	-81.55267532		\$ 900.00		\$ 900.00
R-T3-65	↑ {Route Icon} →	no	6170 veh/day	50 km/hr	NA	42.90771553	-81.42096968		\$ 900.00		\$ 900.00
R-T3-66	← {Route Icon} ↑	no	4357 veh/day	80 km/hr	75 m	42.93310475	-81.42020656		\$ 900.00		\$ 900.00
R-T3-67 ADVANCE	↑ {Route Icon} →	no	4357 veh/day	80 km/hr	75 m	42.93524665	-81.41508849		\$ 900.00		\$ 900.00
R-T3-68	← {Route Icon} ↑	no	12454 veh/day	70 km/hr	75 m	42.94535717	-81.43102469		\$ 900.00		\$ 900.00
R-T3-69 ADVANCE	← {Route Icon} ↑	no	12454 veh/day	70 km/hr	75 m	42.94835697	-81.4269378		\$ 900.00		\$ 900.00
R-T3-70	← {Route Icon} ↑	no	1564 veh/day	50 km/hr	NA	43.10088054	-81.15571657		\$ 900.00		\$ 900.00

NOTE: All final messaging shall be reviewed and finalized by the County prior to fabrication. The document is for preliminary message development only.

Sign Information		Site Information				Approx. Location		Phase			Total Cost
Sign ID	Primary Messaging	Existing Sign	Traffic Volume	Speed Limit	Required Spacing	Latitude	Longitude	PHASE 1 2014-2015	PHASE 2 2015-2018	PHASE 3 2019 +	
R-T3-71	← {Route Icon} →	no	2582 veh/day	50 km/hr	NA	42.99007622	-80.95378551		\$ 900.00		\$ 900.00
R-T3-72	{Route Icon} →	no	6727 veh/day	70 km/hr	75 m	42.94465085	-81.43168094		\$ 900.00		\$ 900.00
R-T3-73	← {Route Icon}	no	3441 veh/day	80 km/hr	75 m	42.94476162	-81.43082951		\$ 900.00		\$ 900.00
R-T3-74 ADVANCE	← {Route Icon}	no	3441 veh/day	80 km/hr	75 m	42.94180367	-81.42684501		\$ 900.00		\$ 900.00
R-T3-75 ADVANCE	{Route Icon} →	no	6727 veh/day	80 km/hr	75 m	42.94166735	-81.43576542		\$ 900.00		\$ 900.00
R-T3-76	{Route Icon} →	no	1573 veh/day	50 km/hr	NA	42.94525642	-81.43177176		\$ 900.00		\$ 900.00
R-T3-77	{Route Icon} →	no	NA	NA	NA	43.205346	-81.6715		\$ 900.00		\$ 900.00
R-T3-78	← {Route Icon}	no	NA	NA	NA	43.207286	-81.671698		\$ 900.00		\$ 900.00
R-T3-79	{Route Icon} →	no	NA	NA	NA	43.204219	-81.557502		\$ 900.00		\$ 900.00
R-T3-80	← {Route Icon}	no	NA	NA	NA	43.203247	-81.554716		\$ 900.00		\$ 900.00
R-T3-81	{Route Icon} →	no	NA	NA	NA	43.004472	-81.556503		\$ 900.00		\$ 900.00
R-T3-82	← {Route Icon}	no	NA	NA	NA	43.00488	-81.554401		\$ 900.00		\$ 900.00
R-T3-83	← {Route Icon}	no	NA	NA	NA	42.998302	-81.394963		\$ 900.00		\$ 900.00
R-T3-84	{Route Icon} →	no	NA	NA	NA	42.999411	-81.397781		\$ 900.00		\$ 900.00
R-T3-85	← {Route Icon}	no	NA	NA	NA	42.991067	-81.392566		\$ 900.00		\$ 900.00
R-T3-86	{Route Icon} →	no	NA	NA	NA	42.992768	-81.392264		\$ 900.00		\$ 900.00
TOTAL NUMBER								0	87	0	
TOTAL COST								\$	- \$ 78,300.00	\$	- \$ 78,300.00

NOTE: All final messaging shall be reviewed and finalized by the County prior to fabrication. The document is for preliminary message development only.



Directional Signage

PUBLIC DESTINATION DIRECTIONAL

Where there is a gap in the existing provincial signage, these sign types will provide vehicular directional information to public County-wide attractions and points of interest.

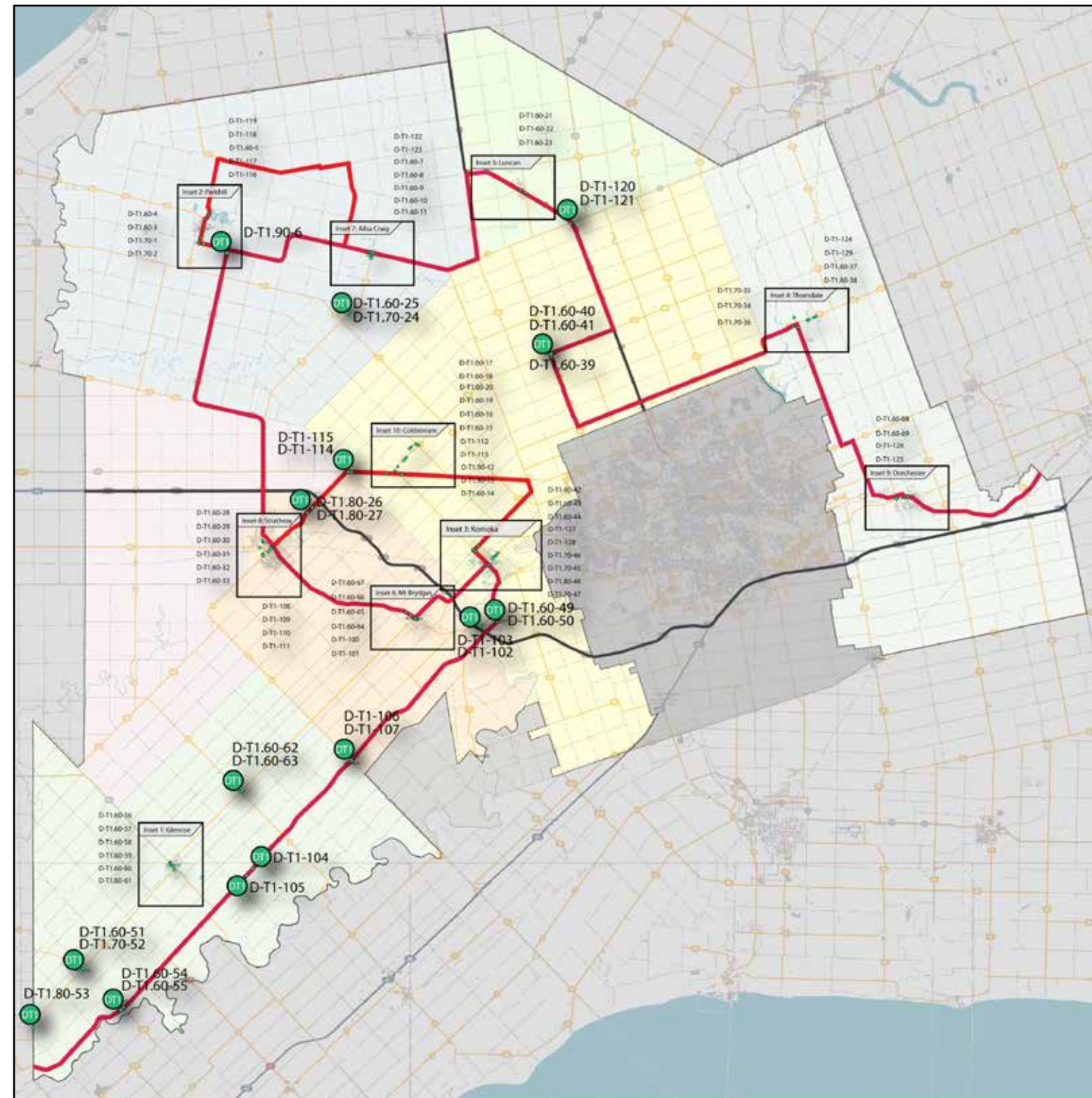

NOTE: All sign placement recommendations within this document are intended to be approximate only. Prior to installation, all sign locations shall be reviewed and adjusted as needed by the client's sign production team to meet all applicable guidelines and bylaws for each location. Site verification by the client is required for final locations of signs. Form:Media will not be responsible for finalizing any locations.

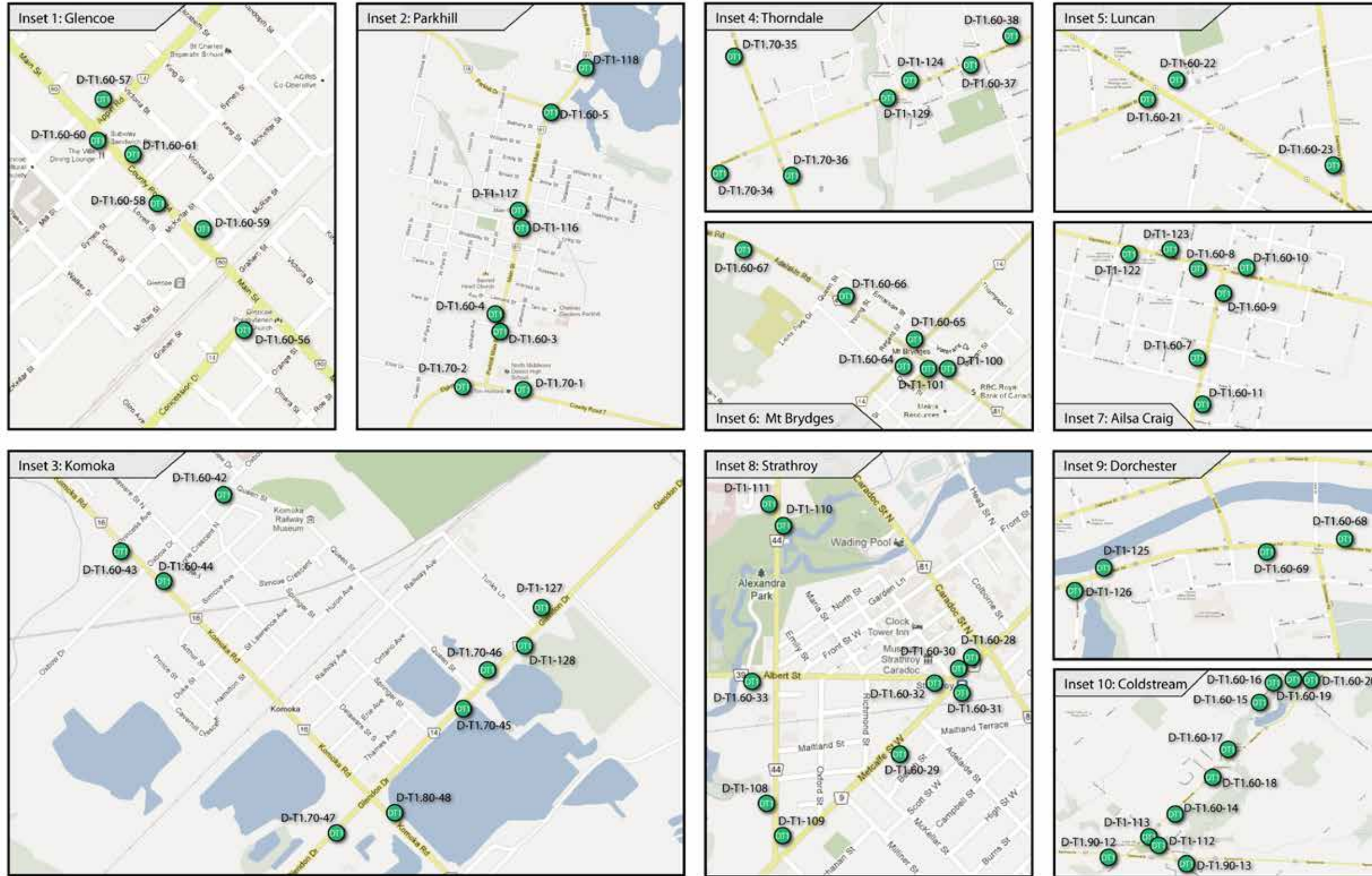

NOTE: All sign placement recommendations within this document are intended to be approximate only. Prior to installation, all sign locations shall be reviewed and adjusted as needed by the client's sign production team to meet all applicable guidelines and bylaws for each location. Site verification by the client is required for final locations of signs. Form:Media will not be responsible for finalizing any locations.

Sign Information				Site Information			Priority			Notes
Sign ID	Direction: Right	Direction: Left	Direction: Straight	Existing Sign	Latitude	Longitude	PHASE 1 2014-2015	PHASE 2 2015-2018	PHASE 3 2019 +	
D-T1.70-1	→ {Icon} Arena → {Icon} Community Centre → {Icon} Sports Field → {Icon} Library			no	43.15286802	-81.68394664			\$ 1,900.00	Note: Relocate service club sign
D-T1.70-2		← {Icon} Library ← {Icon} Community Centre ← {Icon} Sports Field ← {Icon} Arena		no	43.15328864	-81.68874896			\$ 1,900.00	
D-T1.60-3	→ {Icon} Arena → {Icon} Community Centre → {Icon} Sports Field			no	43.15610912	-81.68595156			\$ 1,900.00	Note: Consider mounting sign to light standard
D-T1.60-4		← {Icon} Community Centre ← {Icon} Sports Field ← {Icon} Arena		no	43.15710652	-81.68585546			\$ 1,900.00	Note: Consider mounting sign to light standard
D-T1.60-5	→ {Icon} Arena → {Icon} Community Centre → {Icon} Sports Field → {Icon} Library			no	43.16842196	-81.6818593			\$ 1,900.00	
D-T1.90-6		← {Icon} Library ← {Icon} Community Centre ← {Icon} Sports Field ← {Icon} Arena		no	43.14702322	-81.66290862			\$ 1,900.00	
D-T1.60-7	→ {Icon} Community Centre → {Icon} Sports Field			no	43.14476229	-81.53456242			\$ 1,900.00	Note: Consider mounting sign to light standard
D-T1.60-8	→ {Icon} Community Centre → {Icon} Sports Field			no	43.14708321	-81.53463			\$ 1,900.00	Note: Consider mounting sign to light standard
D-T1.60-9		← {Icon} Town Office ← {Icon} Library		no	43.14637366	-81.53390597			\$ 1,900.00	Note: Parking sign tab can be mounted to new structure below directional sign.
D-T1.60-10		← {Icon} Community Centre ← {Icon} Sports Field	↑ {Icon} Library ↑ {Icon} Town Office	no	43.14697755	-81.53295931			\$ 1,900.00	Note:
D-T1.60-11		← {Icon} Community Centre ← {Icon} Sports Field	↑ {Icon} Library ↑ {Icon} Town Office	no	43.14357607	-81.53473913			\$ 1,900.00	Note: Consider mounting to existing light standard.
D-T1.90-12		← {Icon} Conservation Area ← {Icon} Community Centre ← {Icon} Library ← {Icon} Info Kiosk		no	43.0036292	-81.52123357			\$ 1,900.00	

Sign Information				Site Information			Priority			Notes
Sign ID	Direction: Right	Direction: Left	Direction: Straight	Existing Sign	Latitude	Longitude	PHASE 1 2014-2015	PHASE 2 2015-2018	PHASE 3 2019 +	
D-T1.90-13	→ {Icon} Library → {Icon} Community Centre → {Icon} Conservation Area → {Icon} Info Kiosk			no	43.00320188	-81.50756726			\$ 1,900.00	
D-T1.60-14			↑ {Icon} Library ↑ {Icon} Community Centre ↑ {Icon} Conservation Area ↑ {Icon} Info Kiosk	no	43.00826202	-81.51098685			\$ 1,900.00	
D-T1.60-15	→ {Icon} Conservation Area → {Icon} Sports Field → {Icon} Hiking Trails → {Icon} Info Kiosk			no	43.01999348	-81.50054915			\$ 1,900.00	
D-T1.60-16		← {Icon} Conservation Area ← {Icon} Hiking Trails ← {Icon} Sports Field ← {Icon} Info Kiosk		no	43.02126019	-81.49874859			\$ 1,900.00	
D-T1.60-17	→ {Icon} Conservation Area → {Icon} Sports Field → {Icon} Hiking Trails			no	43.0140169	-81.50346133			\$ 1,900.00	
D-T1.60-18			↑ {Icon} Library ↑ {Icon} Community Centre ↑ {Icon} Conservation Area	no	43.01223039	-81.50566112			\$ 1,900.00	Note: Remove existing Conservation Area sign due to poor condition.
D-T1.60-19	→ {Icon} Conservation Area		↑ {Icon} Library ↑ {Icon} Community Centre	no	43.02218204	-81.49245375			\$ 1,900.00	Note: Remove existing conservation area sign.
D-T1.60-20		← {Icon} Conservation Area ← {Icon} Hiking Trails ← {Icon} Sports Field		no	43.0229182	-81.49503289			\$ 1,900.00	
D-T1.60-21		← {Icon} Library ← {Icon} Community Centre ← {Icon} Sports Field ← {Icon} Arena ← {Icon} Info Kiosk		no	43.18764717	-81.40317214			\$ 1,900.00	Note: Consider mounting to existing light standard

NOTE: All final messaging shall be reviewed and finalized by the County prior to fabrication. The document is for preliminary message development only.

Sign Information				Site Information			Priority			Notes
Sign ID	Direction: Right	Direction: Left	Direction: Straight	Existing Sign	Latitude	Longitude	PHASE 1 2014-2015	PHASE 2 2015-2018	PHASE 3 2019 +	
D-T1-60-22	→ {Icon} Community Centre → {Icon} Library → {Icon} Arena → {Icon} Sports Field → {Icon} Info Kiosk			no	43.1879169	-81.40235434			\$ 1,900.00	Note: Consider mounting to existing light standard
D-T1.60-23	→ {Icon} Community Centre → {Icon} Library → {Icon} Arena → {Icon} Sports Field			no	43.18595176	-81.39751832			\$ 1,900.00	Note: Consider mounting to existing light standard
D-T1.70-24		← {Icon} Public Park ← {Icon} Sports Field		no	43.10684675	-81.55485495			\$ 1,900.00	
D-T1.60-25	→ {Icon} Public Park → {Icon} Sports Field			no	43.10819399	-81.55324059			\$ 1,900.00	Note: Parking tab can be mounted below directional sign
D-T1.80-26	→ {Icon} Arena → {Icon} Sports Field			no	42.98174444	-81.58693611			\$ 1,900.00	Note: Existing sign to be replaced at end of lifespan. Consider increased spacing between signs to improve visibility.
D-T1.80-27	→ {Icon} Arena → {Icon} Sports Field			no	42.97815582	-81.59153921			\$ 1,900.00	Note: Existing sign to be replaced at end of lifespan.
D-T1.60-28	→ {Icon} Community Centre → {Icon} Town Hall → {Icon} Arena → {Icon} Library			no	42.95593027	-81.62209662			\$ 1,900.00	Note: Parking sign could be removed and attached as tab below directional sign.
D-T1.60-29		← {Icon} Library ← {Icon} Community Centre ← {Icon} Town Hall ← {Icon} Arena		no	42.95290878	-81.62577068			\$ 1,900.00	
D-T1.60-30	→ {Icon} Community Centre → {Icon} Town Hall → {Icon} Library → {Icon} Info Kiosk	← {Icon} Arena		no	42.95562243	-81.62267365			\$ 1,900.00	Note: Consider mounting sign to existing light standard.
D-T1.60-31		← {Icon} Library ← {Icon} Community Centre ← {Icon} Town Hall ← {Icon} Info Kiosk		no	42.95493521	-81.62327146			\$ 1,900.00	

Sign Information				Site Information			Priority			Notes
Sign ID	Direction: Right	Direction: Left	Direction: Straight	Existing Sign	Latitude	Longitude	PHASE 1 2014-2015	PHASE 2 2015-2018	PHASE 3 2019 +	
D-T1.60-32		← {Icon} Library ← {Icon} Community Centre ← {Icon} Town Hall ← {Icon} Info Kiosk		no	42.95532791	-81.62427323			\$ 1,900.00	
D-T1.60-33	→ {Icon} Arena → {Icon} Sports Field		↑ {Icon} Library ↑ {Icon} Community Centre	no	42.9554346	-81.63343336			\$ 1,900.00	
D-T1.70-34			↑ {Icon} Library ↑ {Icon} Community Centre ↑ {Icon} Sports Field	no	43.09944776	-81.16010045			\$ 1,900.00	
D-T1.70-35		← {Icon} Library ← {Icon} Community Centre ← {Icon} Sports Field		no	43.10500859	-81.15851867			\$ 1,900.00	
D-T1.70-36	→ {Icon} Library → {Icon} Community Centre → {Icon} Sports Field			no	43.09855074	-81.15501327			\$ 1,900.00	
D-T1.60-37	→ {Icon} Library → {Icon} Community Centre → {Icon} Sports Field			no	43.1050603	-81.14126191			\$ 1,900.00	Note: Parking Sign can be mounted as tab below directional sign.
D-T1.60-38		← {Icon} Library ← {Icon} Community Centre ← {Icon} Sports Field		no	43.10581976	-81.13922785			\$ 1,900.00	
D-T1.60-39		← {Icon} Arena ← {Icon} Community Centre		no	43.07974175	-81.37441549			\$ 1,900.00	
D-T1.60-40	→ {Icon} Sports Field Library			no	43.08075813	-81.37641339			\$ 1,900.00	Note: Consider mounting sign to existing light standard.
D-T1.60-41		← {Icon} Library ← {Icon} Sports Field	↑ {Icon} Community Centre ↑ {Icon} Arena	no	43.08144833	-81.37438771			\$ 1,900.00	
D-T1.60-42	→ {Icon} Library → {Icon} Community Centre → {Icon} Sports Field → {Icon} Info Kiosk		↑ {Icon} Golf Course	no	42.95677942	-81.43925962			\$ 1,900.00	Note: Opposite side of street is used for sign location.

NOTE: All final messaging shall be reviewed and finalized by the County prior to fabrication. The document is for preliminary message development only.

Sign Information				Site Information			Priority			Notes
Sign ID	Direction: Right	Direction: Left	Direction: Straight	Existing Sign	Latitude	Longitude	PHASE 1 2014-2015	PHASE 2 2015-2018	PHASE 3 2019 +	
D-T1.60-43		← {Icon} Library ← {Icon} Community Centre ← {Icon} Sports Field ← {Icon} Golf Course		no	42.95442845	-81.4441658			\$ 1,900.00	
D-T1.60-44	→ {Icon} Library → {Icon} Community Centre → {Icon} Sports Field → {Icon} Golf Course			no	42.95324285	-81.44229049			\$ 1,900.00	Note: Replace existing sign at end of lifespan
D-T1.70-45		← {Icon} Library ← {Icon} Community Centre ← {Icon} Sports Field ← {Icon} Info Kiosk		no	42.948437	-81.42655815			\$ 1,900.00	
D-T1.70-46	→ {Icon} Library → {Icon} Community Centre → {Icon} Sports Field → {Icon} Info Kiosk			no	42.94963806	-81.42521823			\$ 1,900.00	Note: Remove upstream community centre directional sign
D-T1.70-47		← {Icon} Library ← {Icon} Community Centre ← {Icon} Sports Field ← {Icon} Golf Course		no	42.94358362	-81.4331648			\$ 1,900.00	
D-T1.80-48			↑ {Icon} Community Centre ↑ {Icon} Sports Field ↑ {Icon} Library ↑ {Icon} Golf Course	no	42.94420351	-81.43006493			\$ 1,900.00	
D-T1.60-49	→ {Icon} Info Kiosk	← {Icon} Library ← {Icon} Community Centre ← {Icon} Sports Field		no	42.90714433	-81.42271399			\$ 1,900.00	Note: Parking sign tab can be mounted below directional sign.
D-T1.60-50	→ {Icon} Library → {Icon} Community Centre → {Icon} Sports Field → {Icon} Info Kiosk	← {Icon} Info Kiosk		no	42.90771312	-81.41994708			\$ 1,900.00	
D-T1.60-51	→ {Icon} Library → {Icon} Sports Field → {Icon} Town Hall		↑ {Icon} Conservation Area	no	42.68103299	-81.79062345			\$ 1,900.00	
D-T1.70-52		← {Icon} Library ← {Icon} Sports Field ← {Icon} Town Hall		no	42.67940429	-81.79239949			\$ 1,900.00	

Sign Information				Site Information			Priority			Notes
Sign ID	Direction: Right	Direction: Left	Direction: Straight	Existing Sign	Latitude	Longitude	PHASE 1 2014-2015	PHASE 2 2015-2018	PHASE 3 2019 +	
D-T1.80-53	→ {Icon} Conservation Area			no	42.64237026	-81.83493621			\$ 1,900.00	
D-T1.60-54	→ {Icon} Library → {Icon} Community Centre → {Icon} Sports Field → {Icon} Town Hall	← {Icon} Info Kiosk		no	42.65561729	-81.75497013			\$ 1,900.00	
D-T1.60-55		← {Icon} Library ← {Icon} Community Centre ← {Icon} Sports Field ← {Icon} Town Hall	↑ {Icon} Info Kiosk	no	42.65463627	-81.75633708			\$ 1,900.00	Note: Consider mounting to existing light standard
D-T1.60-56		← {Icon} Library ← {Icon} Arena ← {Icon} Sports Field ← {Icon} Town Hall		no	42.74572946	-81.70960278			\$ 1,900.00	Note: Consider mounting sign to existing light standard.
D-T1.60-57		← {Icon} Library ← {Icon} Arena ← {Icon} Sports Field ← {Icon} Town Hall		no	42.75067711	-81.713356			\$ 1,900.00	
D-T1.60-58	→ {Icon} Town Hall	← {Icon} Library		no	42.74848784	-81.7118375			\$ 1,900.00	Note: Consider mounting sign to existing light standard.
D-T1.60-59	→ {Icon} Library	← {Icon} Town Hall		no	42.74785315	-81.71075061			\$ 1,900.00	Note: Consider mounting sign to existing light standard.
D-T1.60-60	→ {Icon} Arena → {Icon} Sports Field			no	42.74991104	-81.71372574			\$ 1,900.00	Note: Consider mounting sign to existing light standard.
D-T1.60-61		← {Icon} Sports Field ← {Icon} Arena		no	42.74957677	-81.71299235			\$ 1,900.00	Note: Consider mounting sign to existing light standard.
D-T1.60-62	→ {Icon} Community Centre → {Icon} Sports Field			no	42.79650666	-81.65012714			\$ 1,900.00	Note: Consider mounting sign to existing light standard.
D-T1.60-63		← {Icon} Community Centre ← {Icon} Sports Field		no	42.79737353	-81.64916037			\$ 1,900.00	
D-T1.60-64	→ {Icon} Library → {Icon} Info Kiosk	← {Icon} Community Centre ← {Icon} Sports Field ← {Icon} Arena		no	42.90917834	-81.49638451			\$ 1,900.00	

Sign Information				Site Information			Priority			Notes
Sign ID	Direction: Right	Direction: Left	Direction: Straight	Existing Sign	Latitude	Longitude	PHASE 1 2014-2015	PHASE 2 2015-2018	PHASE 3 2019 +	
D-T1.60-65	→ {Icon} Community Centre → {Icon} Sports Field → {Icon} Arena	← {Icon} Library ← {Icon} Info Kiosk		no	42.9100636	-81.49536207			\$ 1,900.00	
D-T1.60-66		← {Icon} Community Centre ← {Icon} Sports Field ← {Icon} Arena		no	42.91160203	-81.49938799			\$ 1,900.00	
D-T1.60-67	→ {Icon} Community Centre → {Icon} Sports Field → {Icon} Arena			no	42.91351047	-81.5039041			\$ 1,900.00	
D-T1.60-68		← {Icon} Library ← {Icon} Community Centre ← {Icon} Sports Field ← {Icon} Arena ← {Icon} Info Kiosk		no	42.98854444	-81.05731944			\$ 1,900.00	
D-T1.60-69	→ {Icon} Library → {Icon} Community Centre → {Icon} Sports Field → {Icon} Arena → {Icon} Info Kiosk			no	42.98848979	-81.05986521			\$ 1,900.00	Note: Consider attaching sign to existing light standard.
D-T1-100		← {Icon} Info Kiosk		no	42.90872203	-81.49377251			\$ 1,900.00	
D-T1-101	→ {Icon} Info Kiosk			no	42.90910095	-81.49493235			\$ 1,900.00	
D-T1-102	→ {Icon} Info Kiosk			no	42.90429432	-81.43599273			\$ 1,900.00	

NOTE: All final messaging shall be reviewed and finalized by the County prior to fabrication. The document is for preliminary message development only.

Sign Information				Site Information			Priority			Notes
Sign ID	Direction: Right	Direction: Left	Direction: Straight	Existing Sign	Latitude	Longitude	PHASE 1 2014-2015	PHASE 2 2015-2018	PHASE 3 2019 +	
D-T1-103		← {Icon} Info Kiosk		no	42.90413476	-81.438122			\$ 1,900.00	
D-T1-104		← {Icon} Info Kiosk		no	42.74639727	-81.63971859			\$ 1,900.00	
D-T1-105	→ {Icon} Info Kiosk			no	42.741959	-81.6455999			\$ 1,900.00	
D-T1-106		← {Icon} Info Kiosk		no	42.81630887	-81.55273552			\$ 1,900.00	
D-T1-107	→ {Icon} Info Kiosk			no	42.81716742	-81.5518251			\$ 1,900.00	
D-T1-108	→ {Icon} Info Kiosk			no	42.95138759	-81.63105849			\$ 1,900.00	
D-T1-109		← {Icon} Info Kiosk		no	42.95024908	-81.63087663			\$ 1,900.00	
D-T1-110	→ {Icon} Info Kiosk			no	42.95921972	-81.63083644			\$ 1,900.00	
D-T1-111		← {Icon} Info Kiosk		no	42.96023802	-81.63096785			\$ 1,900.00	
D-T1-112	→ {Icon} Info Kiosk			no	43.00485248	-81.51263667			\$ 1,900.00	
D-T1-113		← {Icon} Info Kiosk		no	43.00548298	-81.51371301			\$ 1,900.00	
D-T1-114	→ {Icon} Info Kiosk			no	43.004695	-81.5547518			\$ 1,900.00	
D-T1-115		← {Icon} Info Kiosk		no	43.00480017	-81.55192067			\$ 1,900.00	
D-T1-116		← {Icon} Info Kiosk		no	43.16200555	-81.68411984			\$ 1,900.00	
D-T1-117	→ {Icon} Info Kiosk			no	43.16300692	-81.68408249			\$ 1,900.00	
D-T1-118	→ {Icon} Info Kiosk			no	43.17085244	-81.67933883			\$ 1,900.00	
D-T1-119		← {Icon} Info Kiosk		no	43.17301168	-81.67923683			\$ 1,900.00	
D-T1-120		← {Icon} Info Kiosk		no	43.16729937	-81.35332123			\$ 1,900.00	
D-T1-121	→ {Icon} Info Kiosk			no	43.16601481	-81.35727111			\$ 1,900.00	
D-T1-122	→ {Icon} Info Kiosk			no	43.14752124	-81.53716989			\$ 1,900.00	
D-T1-123		← {Icon} Info Kiosk		no	43.14745043	-81.53577719			\$ 1,900.00	
D-T1-124	→ {Icon} Info Kiosk	← {Icon} Info Kiosk		no	43.10382715	-81.14564612			\$ 1,900.00	
D-T1-125		← {Icon} Info Kiosk		no	43.10329082	-81.1470694			\$ 1,900.00	
D-T1-126	→ {Icon} Info Kiosk			no	42.9877887	-81.06615207			\$ 1,900.00	
D-T1-127	→ {Icon} Info Kiosk			no	42.9873361	-81.06745893			\$ 1,900.00	
D-T1-128		← {Icon} Info Kiosk		no	42.95204675	-81.4220032			\$ 1,900.00	
D-T1-129	→ {Icon} Info Kiosk	← {Icon} Info Kiosk		no	43.103291	-81.147069			\$ 1,900.00	
TOTAL NUMBER							0	0	99	
TOTAL COST							\$ -	\$ -	\$ 188,100.00	

NOTE: All final messaging shall be reviewed and finalized by the County prior to fabrication. The document is for preliminary message development only.



Information Kiosks

INFORMATION KIOSK – VEHICULAR

It is proposed that Primary Information Kiosks will be located at natural stopping points at the primary entry point into the County from the Highway 402. These units provide orientation maps and directional information as well as details about local amenities for the immediate area or community. A QR code will provide a web-link for supplementary or additional information.

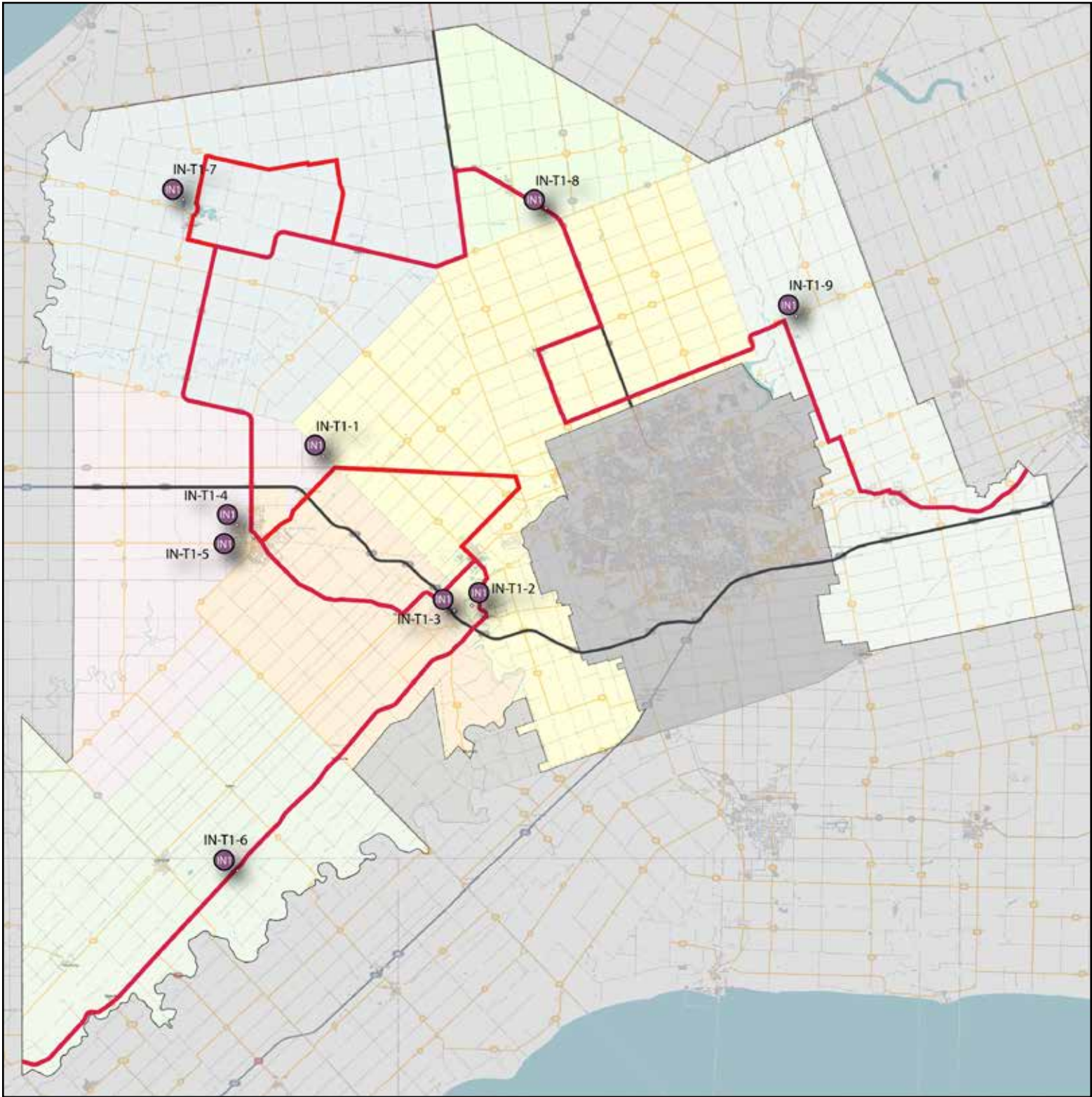

NOTE: All sign placement recommendations within this document are intended to be approximate only. Prior to installation, all sign locations shall be reviewed and adjusted as needed by the client’s sign production team to meet all applicable guidelines and bylaws for each location. Site verification by the client is required for final locations of signs. Form:Media will not be responsible for finalizing any locations.

Sign Information		Site Information				Approx. Location		Phase			Total Cost
Sign ID	Primary Messaging	Existing Sign	Traffic Volume	Speed Limit	Required Spacing	Latitude	Longitude	PHASE 1 2014-2015	PHASE 2 2015-2018	PHASE 3 2019 +	
IN-T1-1	NA	no	NA	NA	NA	43.00468515	-81.55348461			\$ 3,500.00	\$ 3,500.00
IN-T1-2	NA	no	NA	NA	NA	42.90755971	-81.42096747			\$ 3,500.00	\$ 3,500.00
IN-T1-3	NA	no	NA	NA	NA	42.90438677	-81.43688078			\$ 3,500.00	\$ 3,500.00
IN-T1-4	NA	no	NA	NA	NA	42.95993853	-81.63059959			\$ 3,500.00	\$ 3,500.00
IN-T1-5	NA	no	NA	NA	NA	42.95078095	-81.6312418			\$ 3,500.00	\$ 3,500.00
IN-T1-6	NA	no	NA	NA	NA	42.74337074	-81.64249111			\$ 3,500.00	\$ 3,500.00
IN-T1-7	NA	no	NA	NA	NA	43.17194461	-81.67844566			\$ 3,500.00	\$ 3,500.00
IN-T1-8	NA	no	NA	NA	NA	43.16633927	-81.3552716			\$ 3,500.00	\$ 3,500.00
IN-T1-9	NA	no	NA	NA	NA	43.1034312	-81.14632006			\$ 3,500.00	\$ 3,500.00
TOTAL NUMBER								0	0	9	
TOTAL COST								\$ -	\$ -	\$ 31,500.00	\$ 31,500.00

NOTE: All final messaging shall be reviewed and finalized by the County prior to fabrication. The document is for preliminary message development only.



Information Kiosks

INFORMATION KIOSK – PEDESTRIAN

These units will provide orientation maps and related information in areas where larger kiosks are impractical and/or within pedestrian areas. Content will pertain to downtown attractions and nearby amenities.

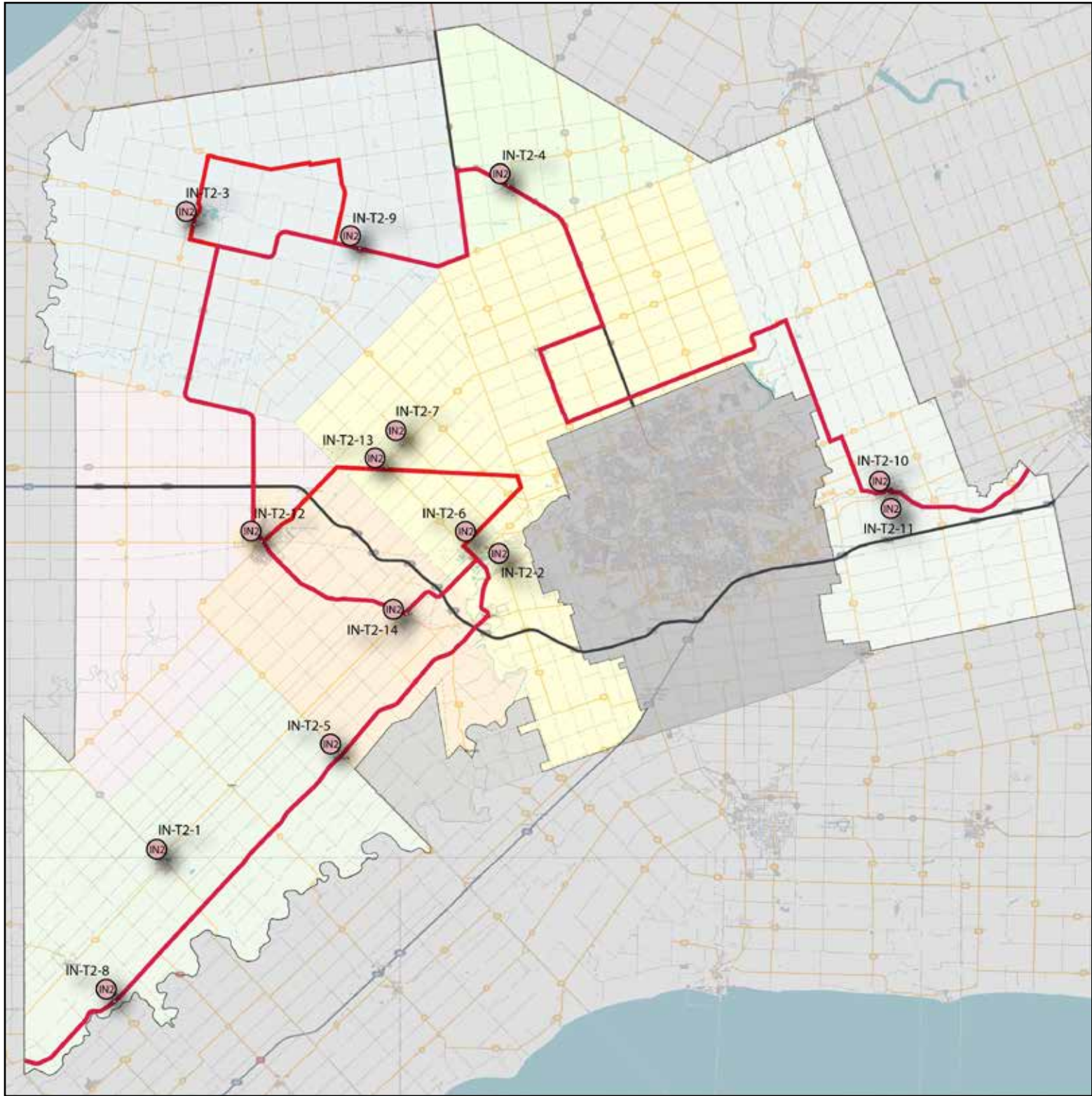

NOTE: All sign placement recommendations within this document are intended to be approximate only. Prior to installation, all sign locations shall be reviewed and adjusted as needed by the client’s sign production team to meet all applicable guidelines and bylaws for each location. Site verification by the client is required for final locations of signs. Form:Media will not be responsible for finalizing any locations.

Sign Information		Site Information				Approx. Location		Phase			Total Cost
Sign ID	Primary Messaging	Existing Sign	Traffic Volume	Speed Limit	Required Spacing	Latitude	Longitude	PHASE 1 2014-2015	PHASE 2 2015-2018	PHASE 3 2019 +	
IN-T2-1	NA	no	NA	NA	NA	42.74727509	-81.71033134			\$ 2,000.00	\$ 2,000.00
IN-T2-2	NA	no	NA	NA	NA	42.95214	-81.42389756			\$ 2,000.00	\$ 2,000.00
IN-T2-3	NA	no	NA	NA	NA	43.16255053	-81.68423653			\$ 2,000.00	\$ 2,000.00
IN-T2-4	NA	no	NA	NA	NA	43.18802323	-81.40373942			\$ 2,000.00	\$ 2,000.00
IN-T2-5	NA	no	NA	NA	NA	42.81805236	-81.55411473			\$ 2,000.00	\$ 2,000.00
IN-T2-6	NA	no	NA	NA	NA	42.95560465	-81.43444598			\$ 2,000.00	\$ 2,000.00
IN-T2-7	NA	no	NA	NA	NA	43.02005218	-81.49923181			\$ 2,000.00	\$ 2,000.00
IN-T2-8	NA	no	NA	NA	NA	42.65519069	-81.75518819			\$ 2,000.00	\$ 2,000.00
IN-T2-9	NA	no	NA	NA	NA	43.14714444	-81.53666917			\$ 2,000.00	\$ 2,000.00
IN-T2-10	NA	no	NA	NA	NA	42.98749572	-81.06660931			\$ 2,000.00	\$ 2,000.00
IN-T2-11	NA	no	NA	NA	NA	42.98502131	-81.05784443			\$ 2,000.00	\$ 2,000.00
IN-T2-12	NA	no	NA	NA	NA	42.95623906	-81.6242202			\$ 2,000.00	\$ 2,000.00
IN-T2-13	NA	no	NA	NA	NA	43.00457031	-81.51282936			\$ 2,000.00	\$ 2,000.00
IN-T2-14	NA	no	NA	NA	NA	42.9088614	-81.49478736			\$ 2,000.00	\$ 2,000.00
TOTAL NUMBER								0	0	14	
TOTAL COST								\$ -	\$ -	\$ 28,000.00	\$ 28,000.00

NOTE: All final messaging shall be reviewed and finalized by the County prior to fabrication. The document is for preliminary message development only.

PRELIMINARY PHASED COSTING ESTIMATES FOR SIGNAGE IMPLEMENTATION								
Sign Information		Phase Information			Costing Details			
Sign Type	Sign Description	PHASE	# IN PHASE	PHASE PARAMETERS	COST PER SIGN	PHASE 1 TOTAL 2014-2015 Implementation	PHASE 2 TOTAL 2015-2019 Implementation (1 year overlap)	PHASE 3 TOTAL 2020 & Beyond Implementation
G-T1	COUNTY GATEWAY SIGN - PRIMARY	1	11		\$ 6,000.00	\$ 66,000.00	\$ -	\$ -
G-T2	COUNTY GATEWAY SIGN - SECONDARY	1	30		\$ 1,900.00	\$ 57,000.00	\$ -	\$ -
G-T3	LOWER TIER MUNICIPAL GATEWAY SIGN	3	39		\$ 2,400.00	\$ -	\$ -	\$ 93,600.00
R-T1	ROUTE INTRODUCTION SIGN	2	29		\$ 1,700.00	\$ -	\$ 49,300.00	\$ -
R-T2	ROUTE ASSURANCE MARKERS	2	26		\$ 900.00	\$ -	\$ 23,400.00	\$ -
R-T3	ROUTE DIRECTIONAL MARKER	2	87		\$ 900.00	\$ -	\$ 78,300.00	\$ -
D-T1	PUBLIC DESTINATION DIRECTIONAL	3	99		\$ 1,900.00	\$ -	\$ -	\$ 188,100.00
IN-T1	INFORMATION KIOSK - VEHICULAR	3	0		\$ 3,500.00	\$ -	\$ -	\$ 31,500.00
IN-T2	INFORMATION KIOSK - PEDESTRIAN	3	0		\$ 2,000.00	\$ -	\$ -	\$ 28,000.00
BQ-T1	BARN QUILT IDENTIFIERS	3	TBD (min. 30)	*Note installation locations and quantities to be determined at a later date by the County	\$ 900.00			\$ 27,000.00
HR-T1	HERITAGE RIVER IDENTIFICATION	3	TBD (min. 4)	*Note installation locations and quantities to be determined at a later date by the County	\$ 1,000.00			\$ 4,000.00
DS-T1	PUBLIC DESTINATION IDENTITY	3	TBD (min. 1)	*Note installation locations and quantities to be determined at a later date by the County	\$ 2,500.00			\$ 2,500.00
D-T5-60	PAY-TO-PLAY SIGNAGE SINGLE	3	TBD (Estimated ~65)	*Note installation locations and quantities to be determined at a later date by the County	\$ 1,700.00			\$ 110,500.00
D-T5-70	PAY-TO-PLAY SIGNAGE - MULTIPLE	3	TBD (Estimated ~5)	*Note installation locations and quantities to be determined at a later date by the County	\$ 1,900.00			\$ 9,500.00
Sub-Total						\$ 123,000.00	\$ 151,000.00	\$ 494,700.00
INSTALLATION & FOOTINGS (10%)						\$ 12,300.00	\$ 15,100.00	\$ 49,470.00
COMPLETE PHASE 1, 2, & 3 IMPLEMENTATION TOTALS						\$ 135,300.00	\$ 166,100.00	\$ 544,170.00

\$ 845,570.00

Appendices



middlesex
c o u n t y

DESIGN FABRICATION SPECIFICATIONS & USER MANUAL

Table of Contents

General	<ul style="list-style-type: none"> 00-00 Cover 00-01 Reference All Signs 00-02 Reference All Signs 00-03 General Requirements 00-04 Colour Schedule
Gateway Signage	<ul style="list-style-type: none"> 01-01 County Gateway Sign - Primary 01-02 County Gateway Sign - Secondary 01-03 Lower Tier Municipal Gateway Sign 01-04 Community Gate Sign
Themed Route Signage	<ul style="list-style-type: none"> 02-01 Route Introduction 02-02 Route Assurance & Route Directional Marker
Identification Signage	<ul style="list-style-type: none"> 03-01 Municipal Amenity Identification 03-02 Parking Identification & Parking Directional 03-03 Heritage River Identification
Information Kiosks	<ul style="list-style-type: none"> 04-01 Information Kiosk - Vehicular 04-02 Information Kiosk - Pedestrian
Directional Signage	<ul style="list-style-type: none"> 05-01 Public Destination Directional - Rural 05-02 Public Destination Directional - Urban 05-03 Community Assurance Signs 05-04 Pay-to-Play Signage
Ancillary Signage	<ul style="list-style-type: none"> 06-01 Interpretive Panels (Barn Quilt Sites and/or Heritage Sites) 06-01 Interpretive Markers (Barn Quilt Sites and/or Heritage Sites) 06-02 Service Club Sign



● County Gateway Sign - Primary

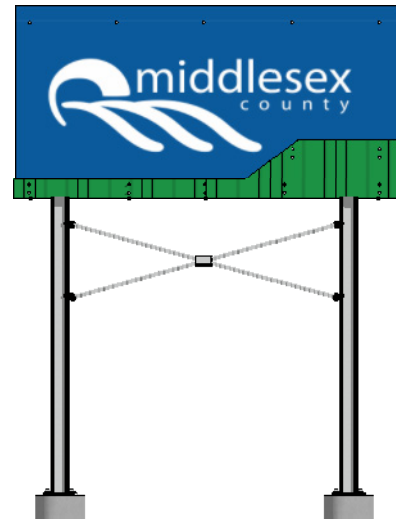

● County Gateway Sign - Secondary

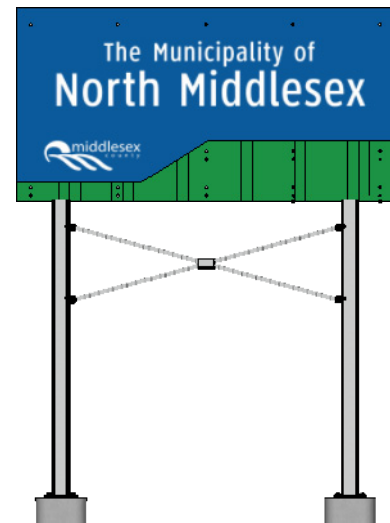

● Lower Tier Municipal Gateway Sign

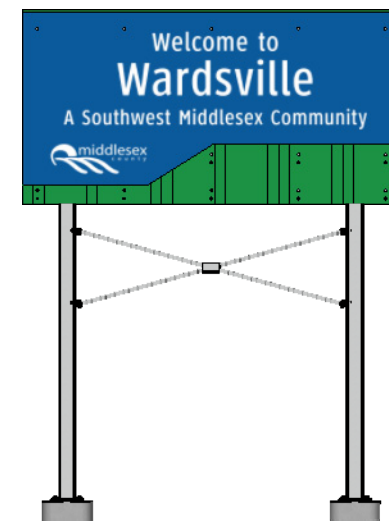

● Community Gateway Sign

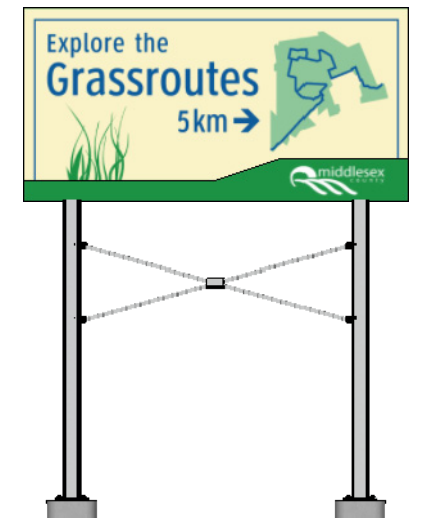

● Route Introduction

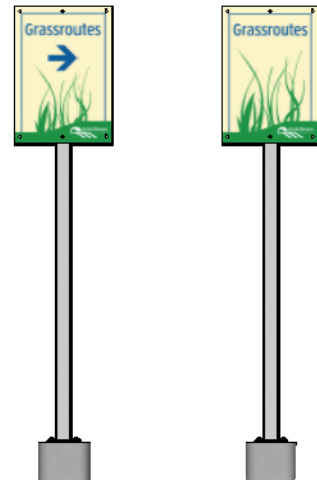

● Route Assurance Marker

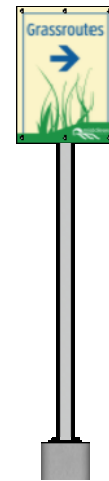

● Route Directional Marker

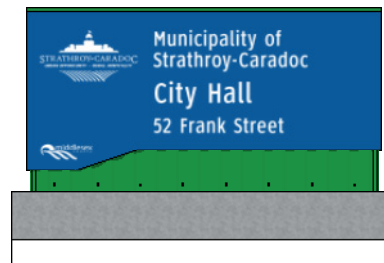

● Municipal Amenity Identification



● Parking Identification & Parking Directional

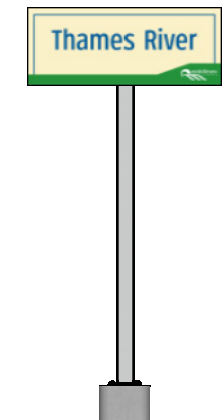

● Heritage River Identification



● Information Kiosk - Vehicular



● Information Kiosk - Vehicular

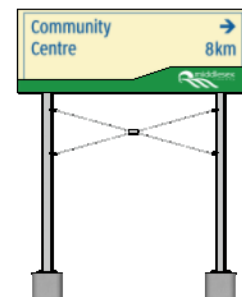

● Public Destination Directional - Rural

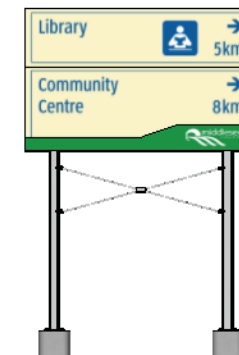

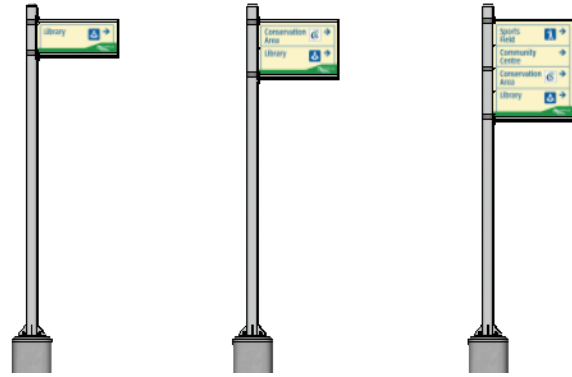

● Public Destination Directional - Urban

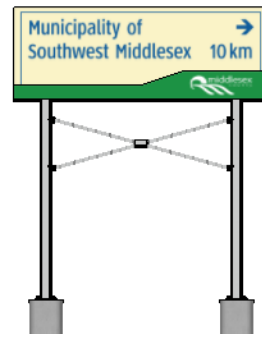

● Pay-to-Play Signage

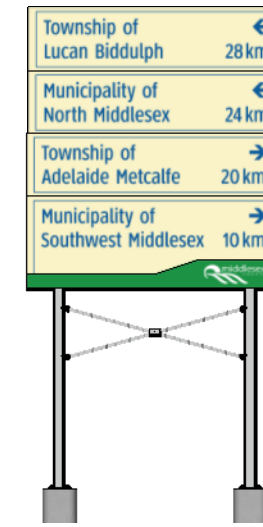

● Interpretive Panel (Barn Quilt Sites and/or Heritage Sites)

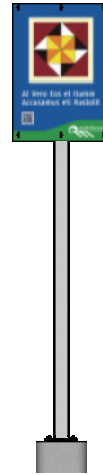

● Interpretive Marker (Barn Quilt Sites and/or Heritage Sites)

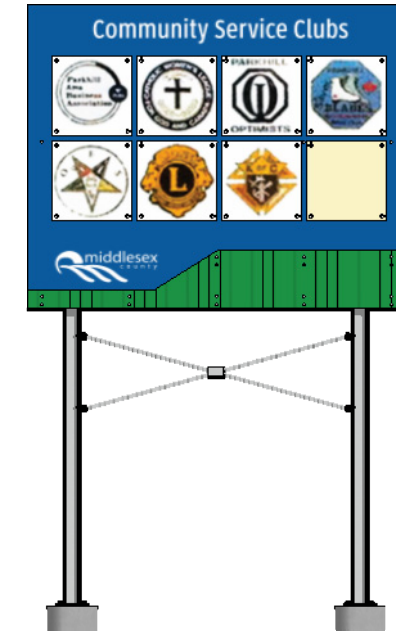

● Service Club Sign

General Requirements

All workmanship shall be square and true with a high degree of architectural finish. It will be the responsibility of the contractor to inspect all raw materials for defects prior to fabrication. Workmanship and finishing will be inspected before transportation to the site as well as after installation. Responsibility for defects in materials, fabrication, or finishing will be assumed by the contractor.

Fastening hardware shall be stainless steel or heavy coat galvanized steel. Fastening holes in sign faces and structures shall be pre-drilled and de-burred prior to paint finishing.

All structural welding shall be executed to best trade practice. Welds must be cleaned and ground smooth as necessary to facilitate proper fit and finishing.

Material samples shall be presented to the client prior to full-scale fabrication for client approval.

The contractor shall make every effort to maintain the safety of the work site(s) and avoid ongoing unsightly conditions. All refuse and discarded materials shall be removed at the contractor's expense. All disturbed landscaping and hardscaping, e.g. asphalt, concrete, shall be repaired to its original condition as the work is completed.

All signs installed on highways shall incorporate a breakaway bolt construction at the footing of the sign per County standards.

Submittals and Approvals

Where signs of the same type are to be produced, one typical detail accompanied by a graphic schedule shall be submitted. The contractor will be responsible for obtaining all permits and adherence to laws and bylaws within the jurisdiction. Where applicable, approved drawings from a structural engineer licensed in Ontario shall be supplied by the fabricator.

Signage installation locations shall be reviewed and approved by the roads authority having jurisdiction.

Any font license purchases required to layout final sign texts shall be the responsibility of the fabricator.

Provided Documents

The successful contractor will be provided design templates for use in production (one for each sign type). These files will include all graphics and logos in vector format as well as pantone colour specifications. Changeable text will be inserted as editable fonts. It will be the responsibility of the fabricator to purchase a license for all fonts for use of the editable templates.

Paint Finishes

Matthew's exterior grade architectural sign paint for metal substrates or approved equal. Powder-coat painting process is an allowable alternative if powdercoat equivalent colour matches are submitted for approval prior to use. All painted surfaces shall be protected with a graffiti-resistant polyurethane clear-coat finish with a gloss sheen.

- P1** Matthew's Paint -
White Wonder MP32071, gloss sheen
- P2** Matthew's Paint -
Custom Paint: Colour Match Pantone 294C
- P3** Matthew's Paint -
Custom Paint: Colour Match Pantone 363C
- P4** Matthew's Paint -
Custom Paint: Colour Match Pantone 7499C

Vinyl Finishes

Exterior Grade Avery Vinyl Film or approved equal. High visibility reflective films shall be used where designated. Any substitutions and/or custom colours require sample to be provided by fabricator for approval prior to use.

- V1** Avery 900 Supercast Opaque Film -
White SC 900-101-O
- V1_R** Avery HV 1200 High Visibility Reflective Film -
White HV 1200-101-R
- V2** Custom Vinyl: Colour Match Pantone 294C
- V2_R** High Visibility Reflective Film - Custom Vinyl:
Colour Match Pantone 294C
- V3** Custom Vinyl: Colour Match Pantone 363C

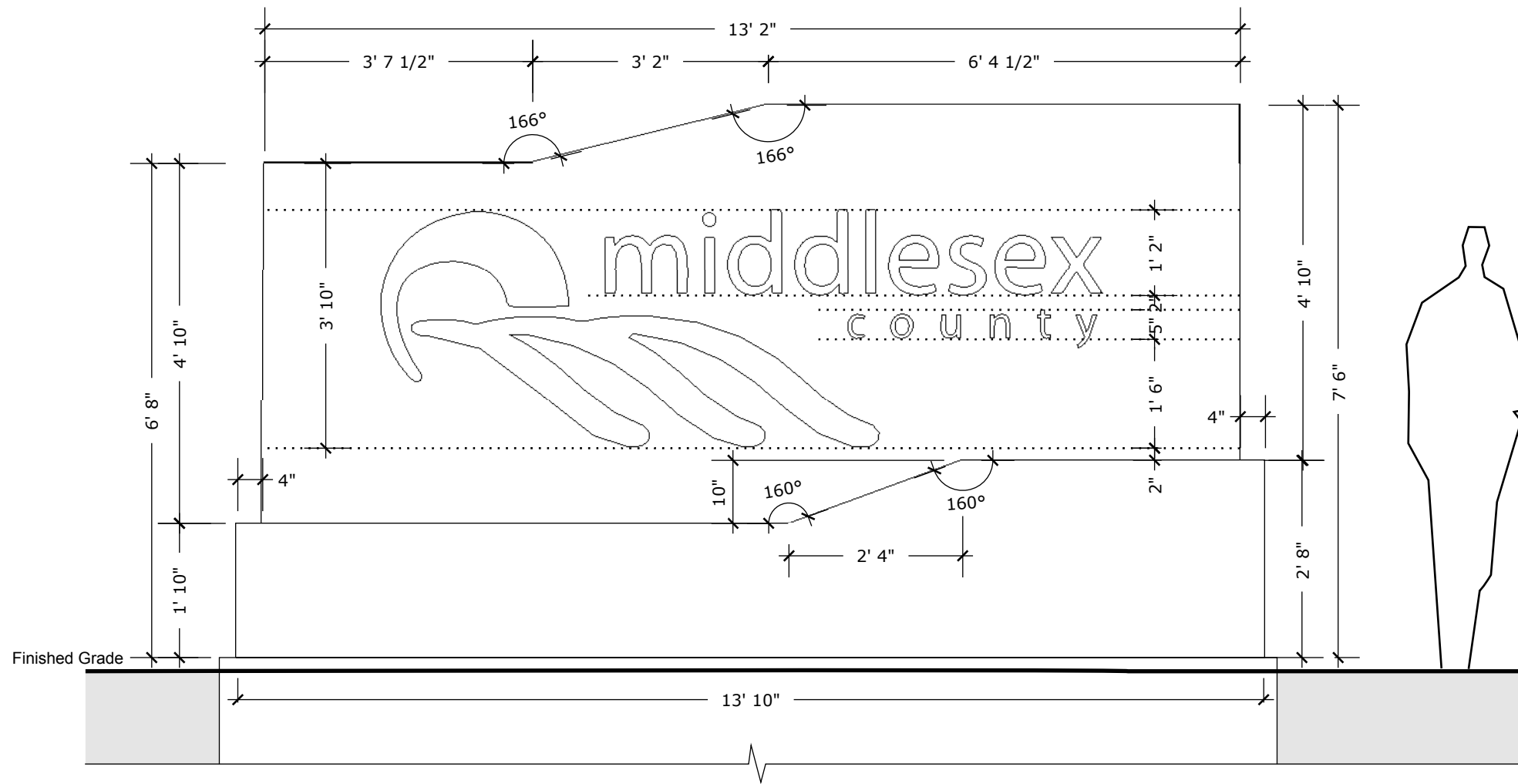

1 Front Elevation
Scale: 1/2" = 1' (1:24)

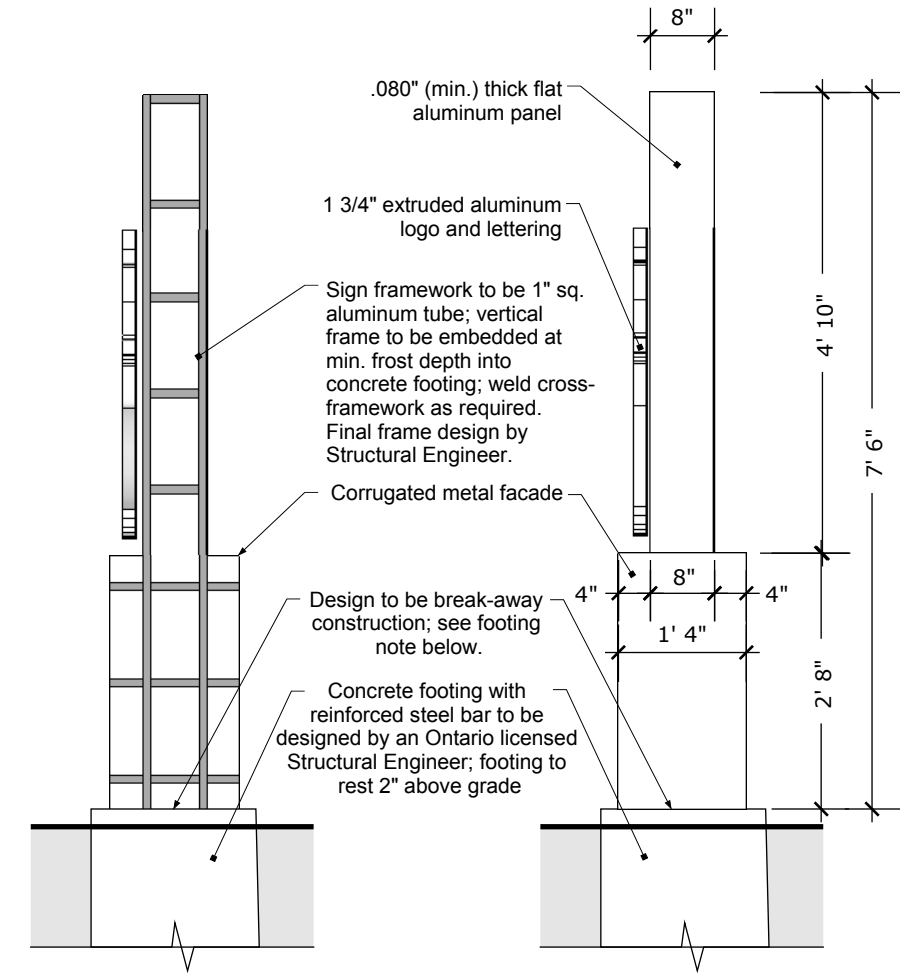

2 Right Side Elevation
Scale: 1/2" = 1' (1:24)

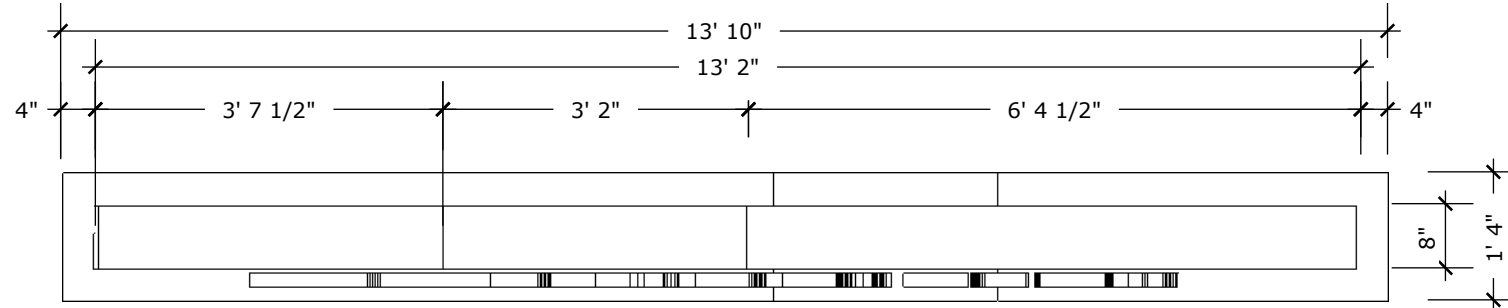

3 Top Elevation
Scale: 1/2" = 1' (1:24)

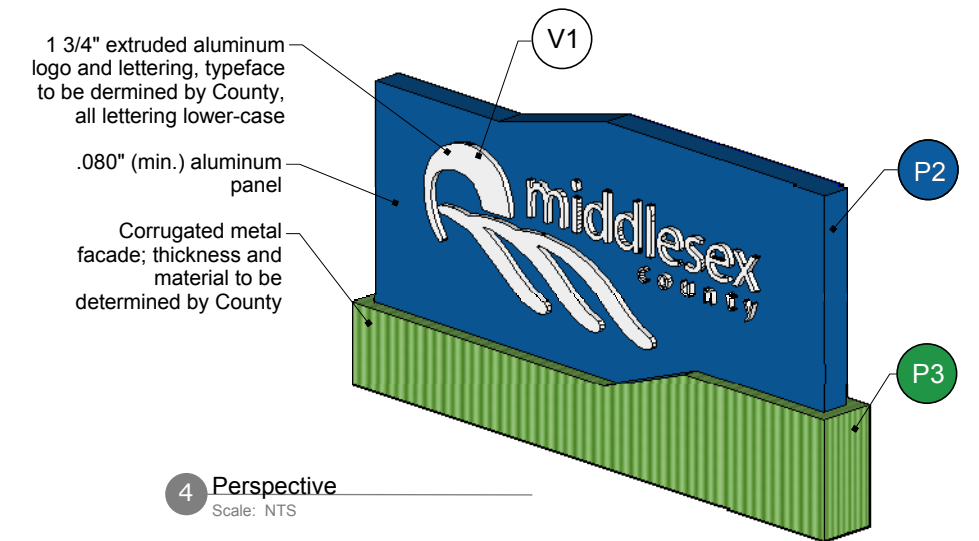

4 Perspective
Scale: NTS

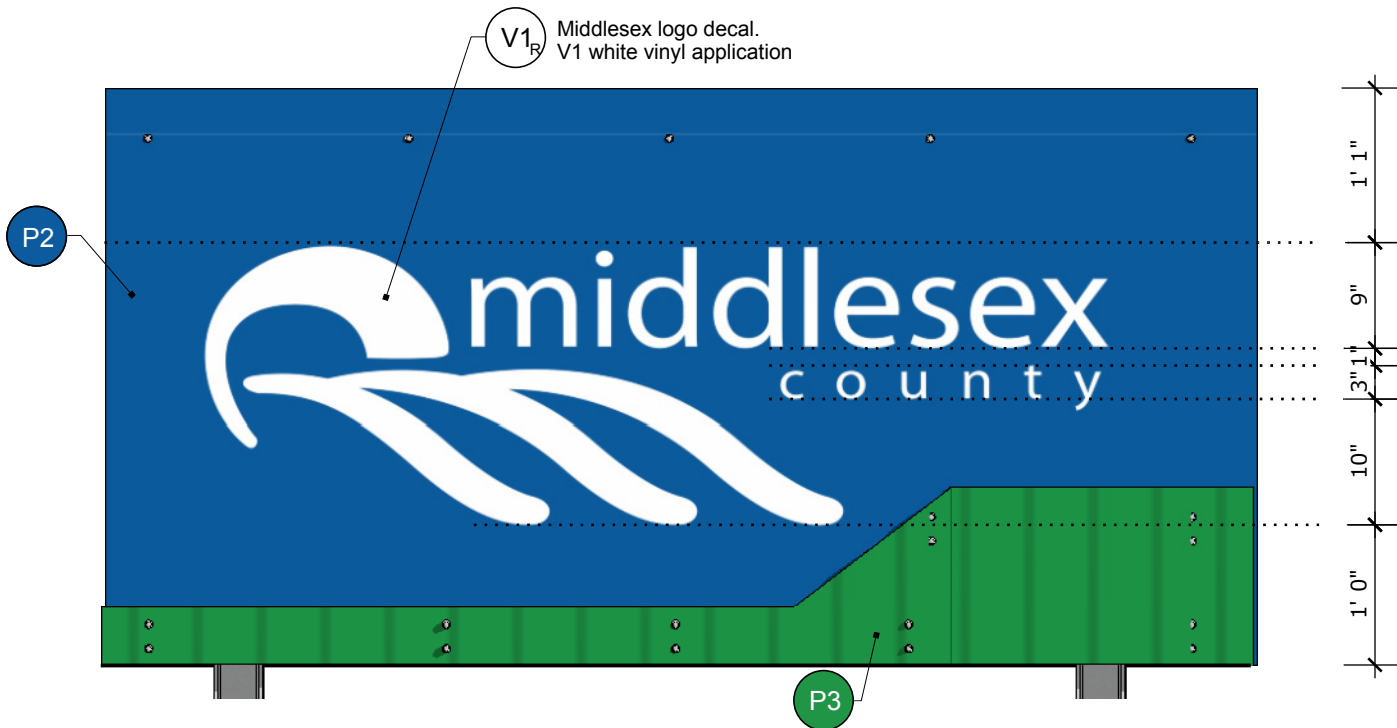

3 Font Enlargement
Scale: 3/4" = 1' (1:16)

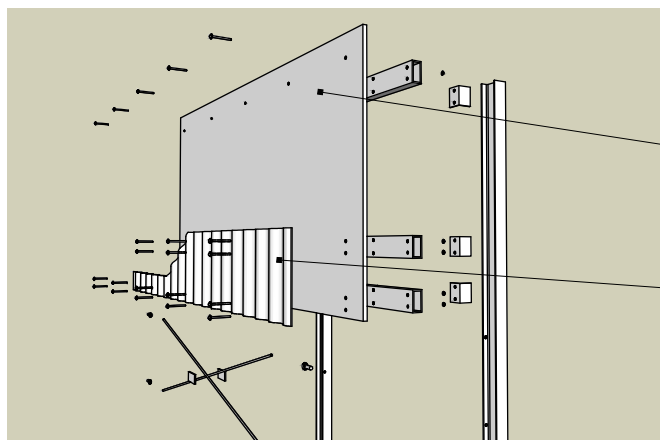

Fabrication Option 1

Plywood with aluminum adhered to surface by County approved epoxy. Paint back of sign to match face (P2).

Corrugated metal facade, bolted to plywood as shown, thickness and material to be determined by County.

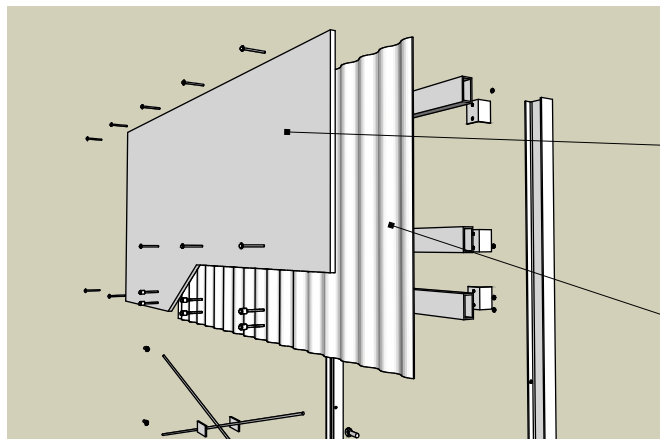

Fabrication Option 2

Plywood with aluminum adhered to surface by County approved epoxy; plywood to be bolted to corrugated metal backing as shown.

Corrugated metal backing, thickness and material to be determined by County. Paint back of sign to match face (P3).

Note: The Municipality is required to choose a fabrication option best fit for their in-house capabilities upon the implementation stage of the project. Once an option is chosen, it must be applied to all future signs for consistency.

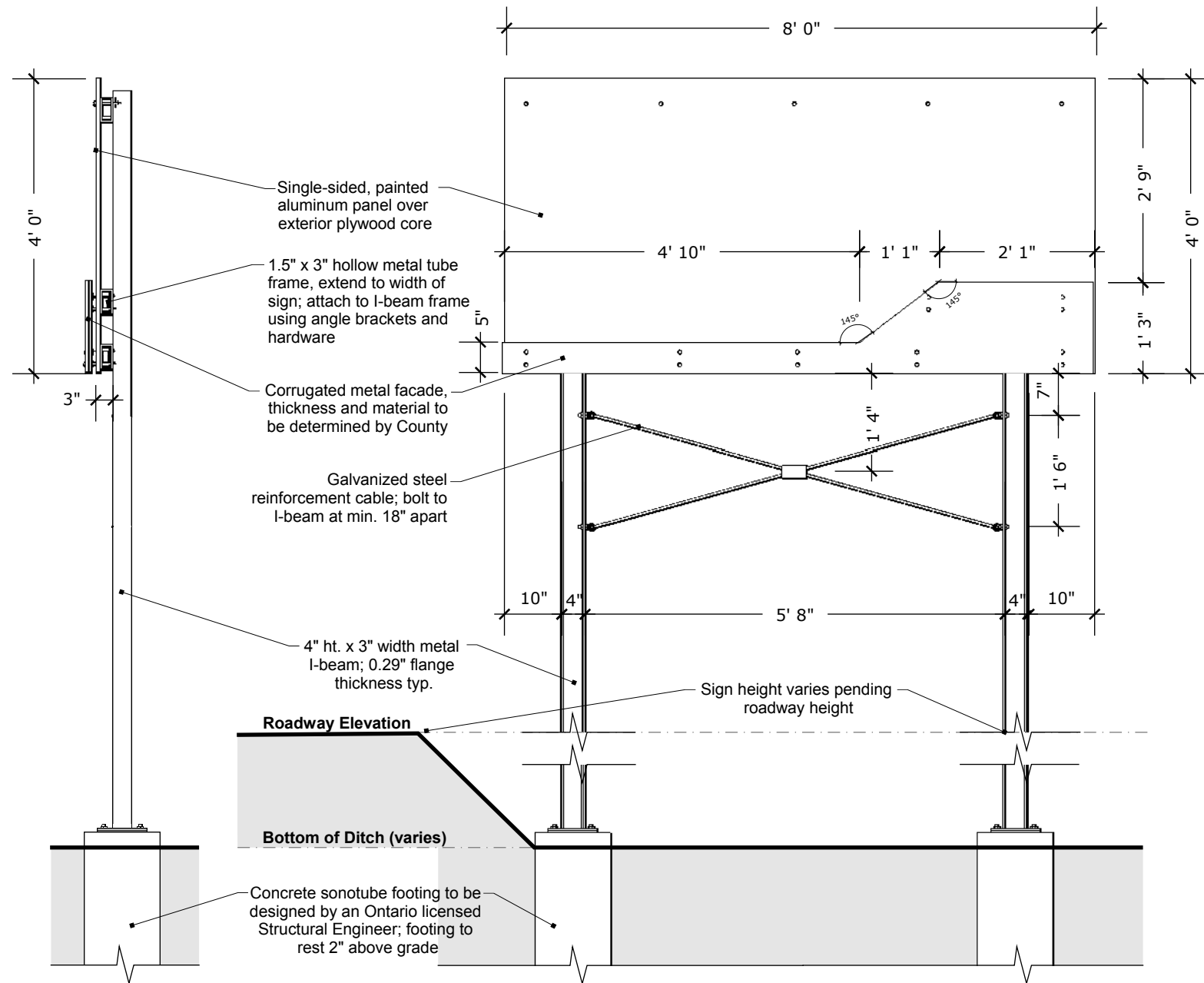

2 Side Elevation
Scale: 1/2" = 1' (1:24)

1 Front Elevation
Scale: 1/2" = 1' (1:24)

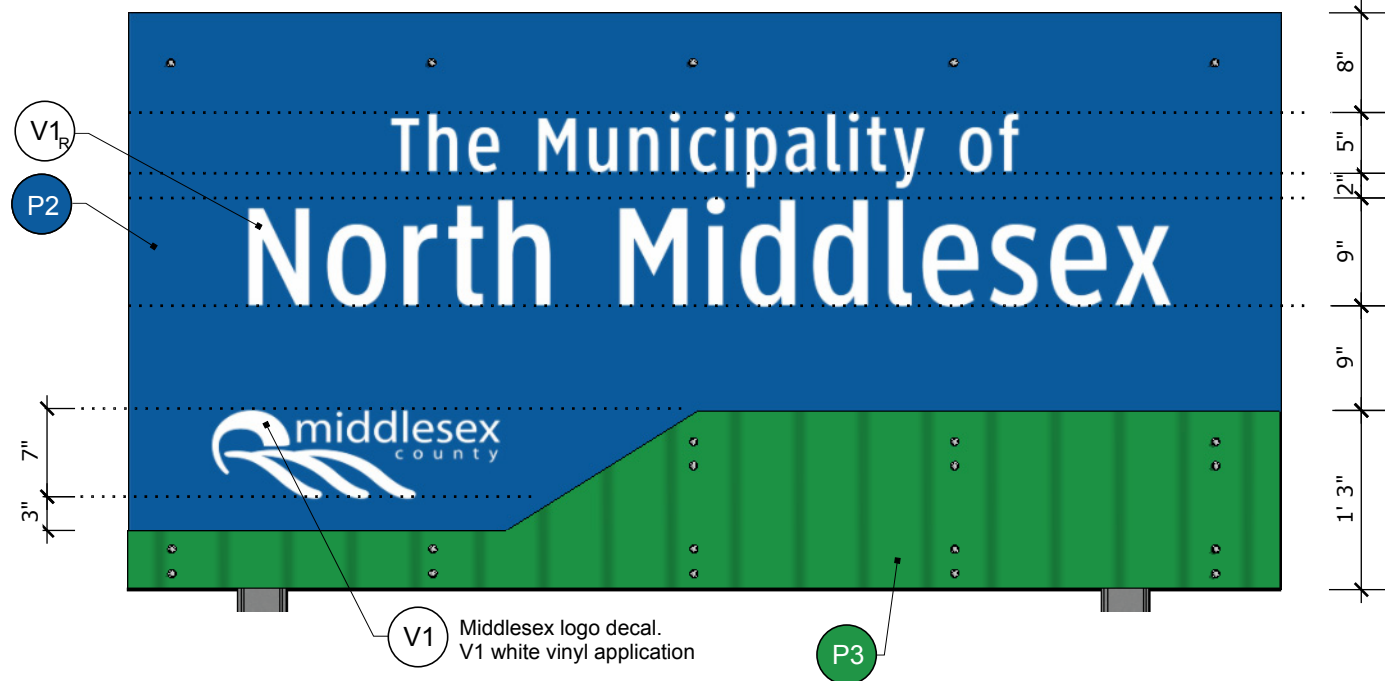

NOTE:
This sign type is available on a voluntary basis.

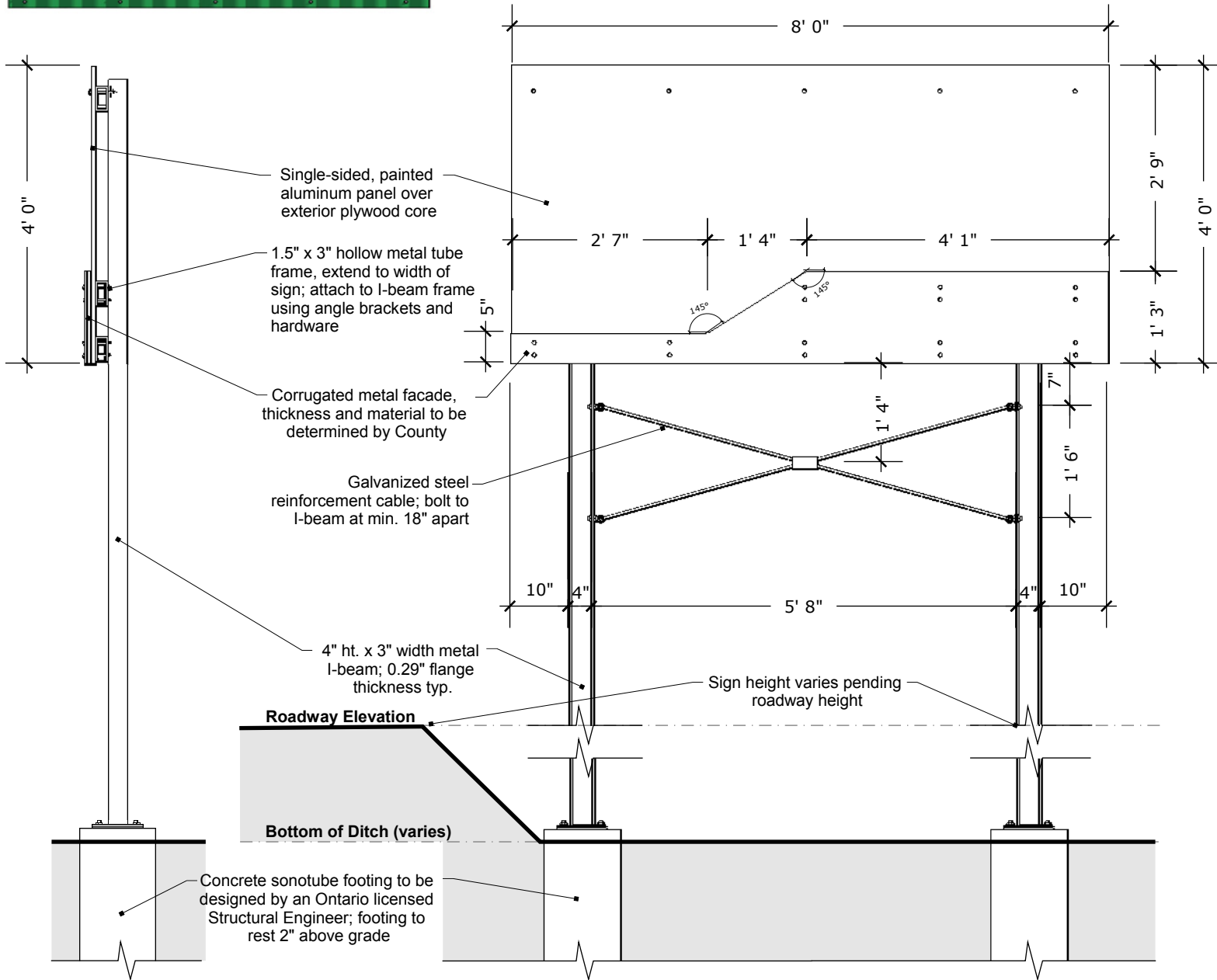
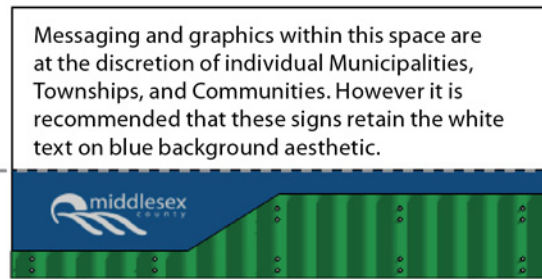

3 Font Enlargement
Scale: 1/2" = 1' (1:24)

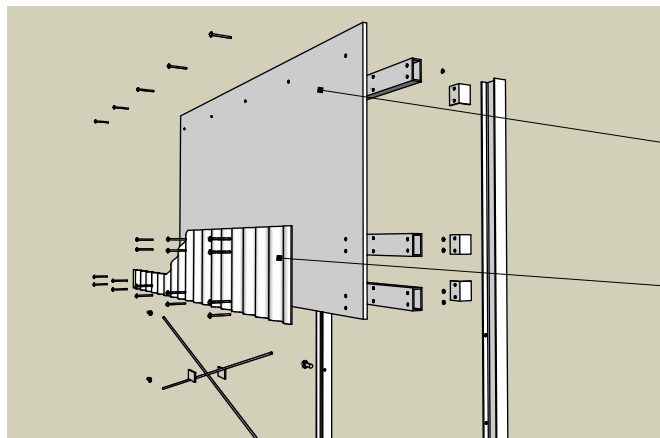

Fabrication Option 1

Note: The Municipality is required to choose a fabrication option best fit for their in-house capabilities upon the implementation stage of the project. Once an option is chosen, it must be applied to all future signs for consistency.

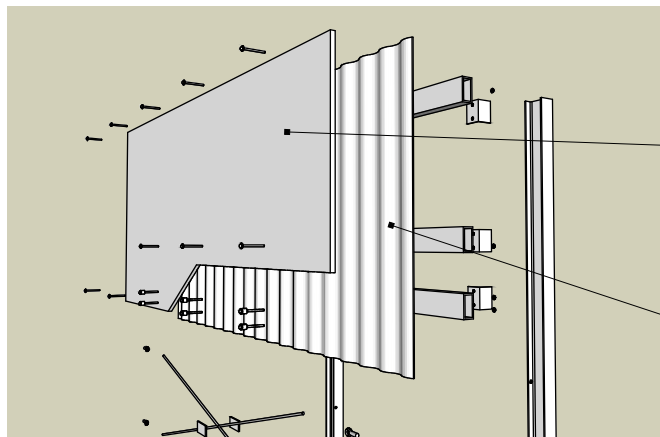

Fabrication Option 2

2 Side Elevation
Scale: 1/2" = 1' (1:24)

1 Front Elevation
Scale: 1/2" = 1' (1:24)



NOTE:
This sign type is available on a voluntary basis.

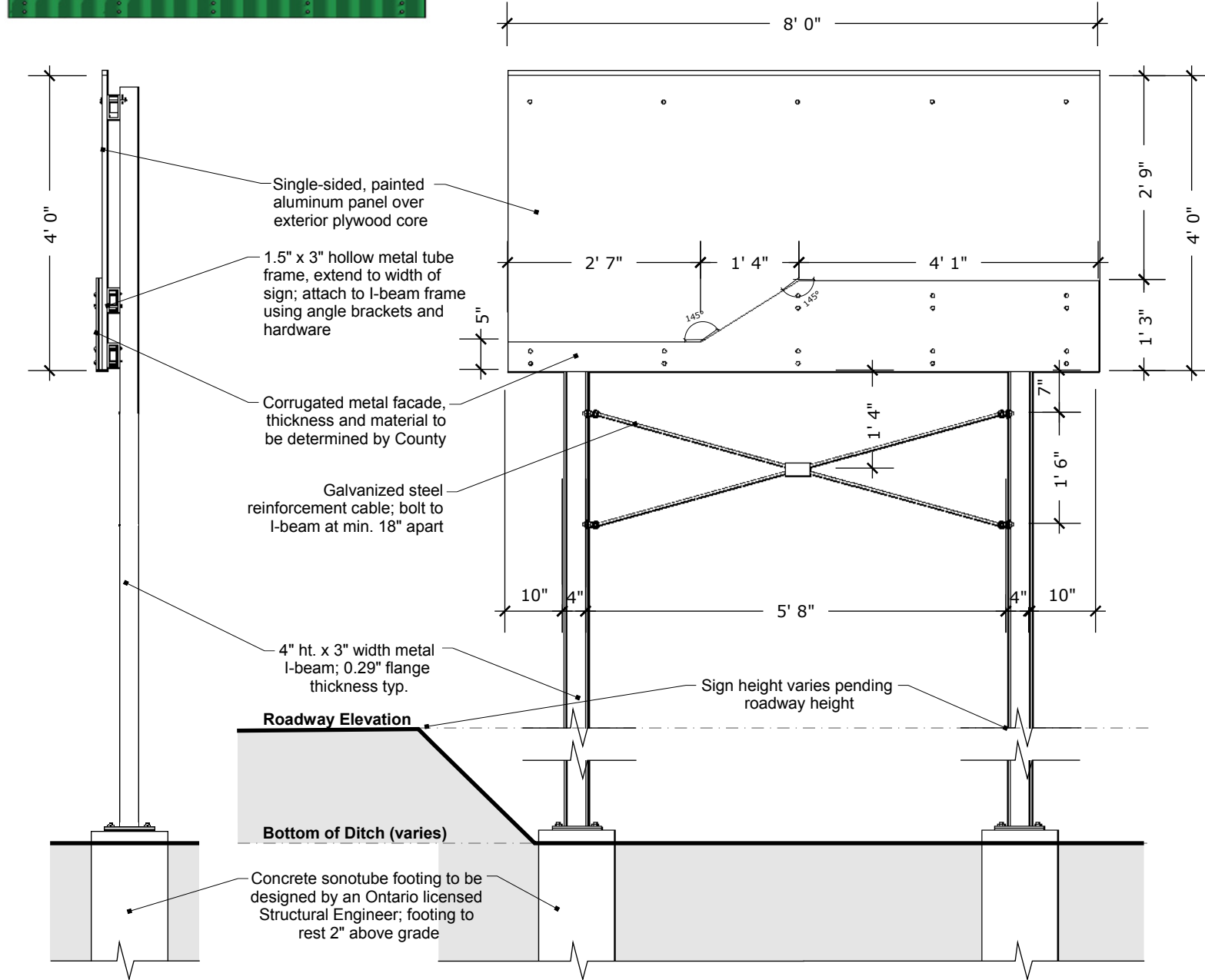
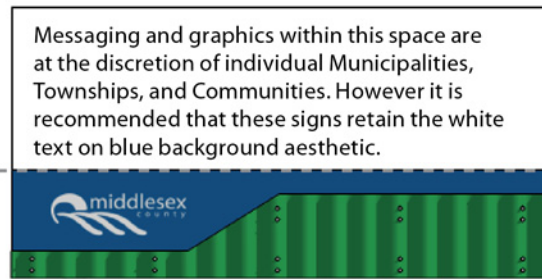

3 Font Enlargement
Scale: 3/4" = 1' (1:16)

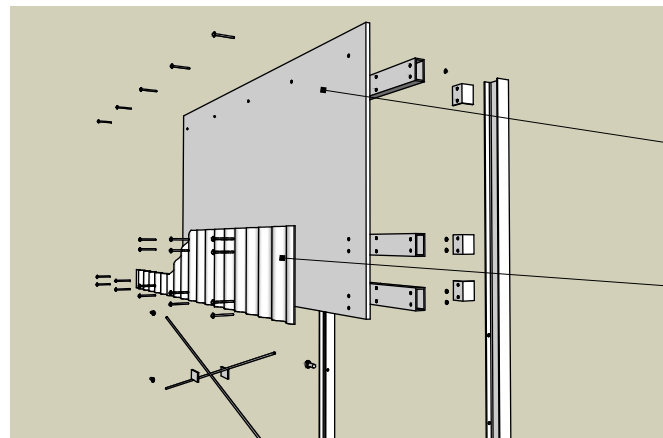

Fabrication Option 1

Note: The Municipality is required to choose a fabrication option best fit for their in-house capabilities upon the implementation stage of the project. Once an option is chosen, it must be applied to all future signs for consistency.

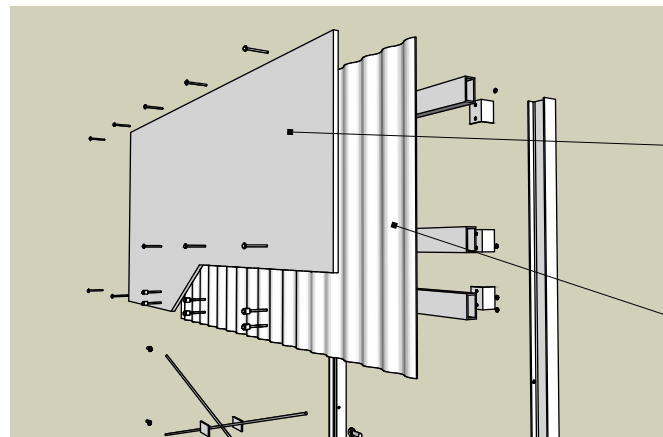

Fabrication Option 2

2 Side Elevation
Scale: 1/2" = 1' (1:24)

1 Front Elevation
Scale: 1/2" = 1' (1:24)



3 Font Enlargement
Scale: 3/4" = 1' (1:16)

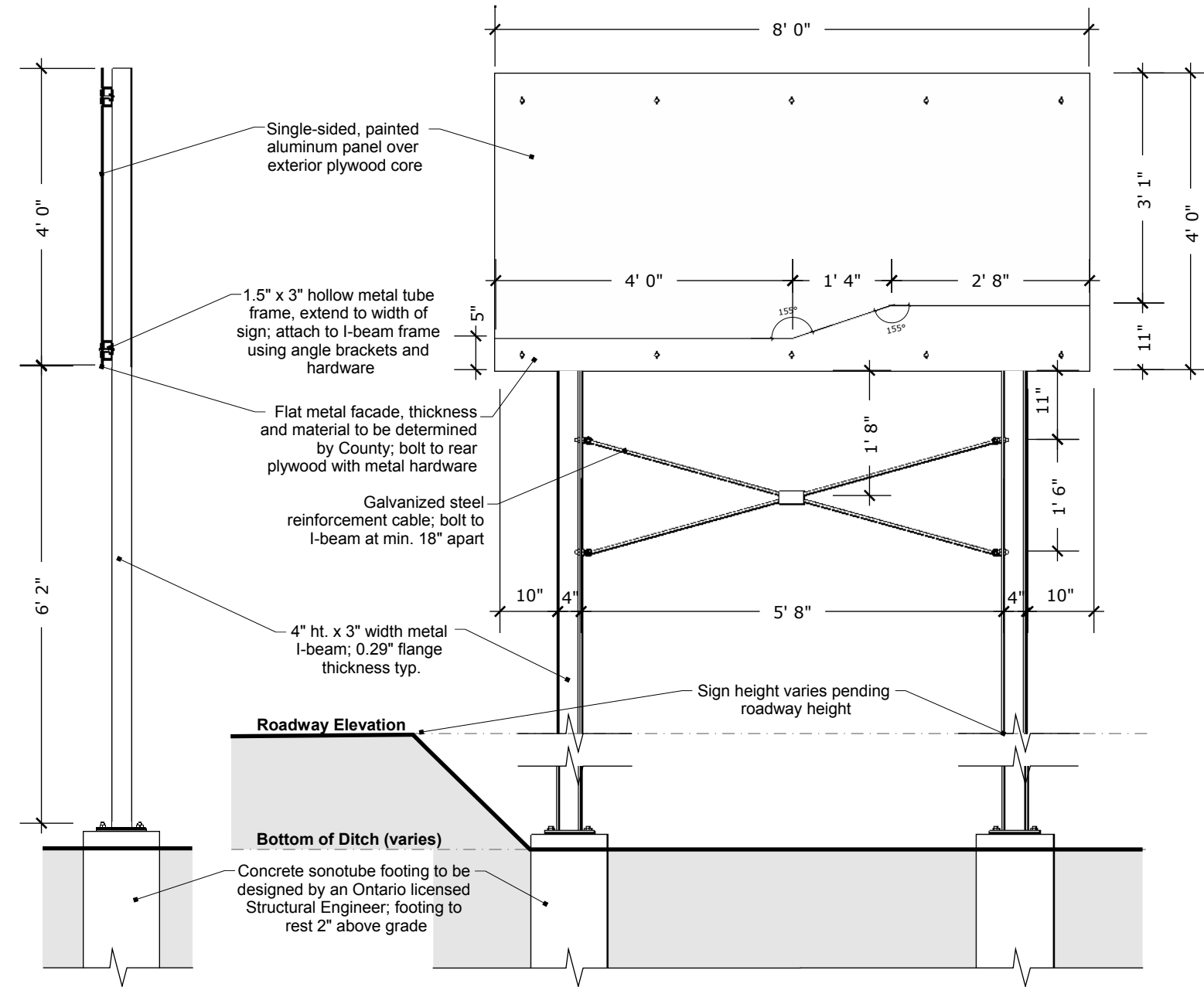

2 Side Elevation
Scale: 1/2" = 1' (1:24)

1 Front Elevation
Scale: 1/2" = 1' (1:24)

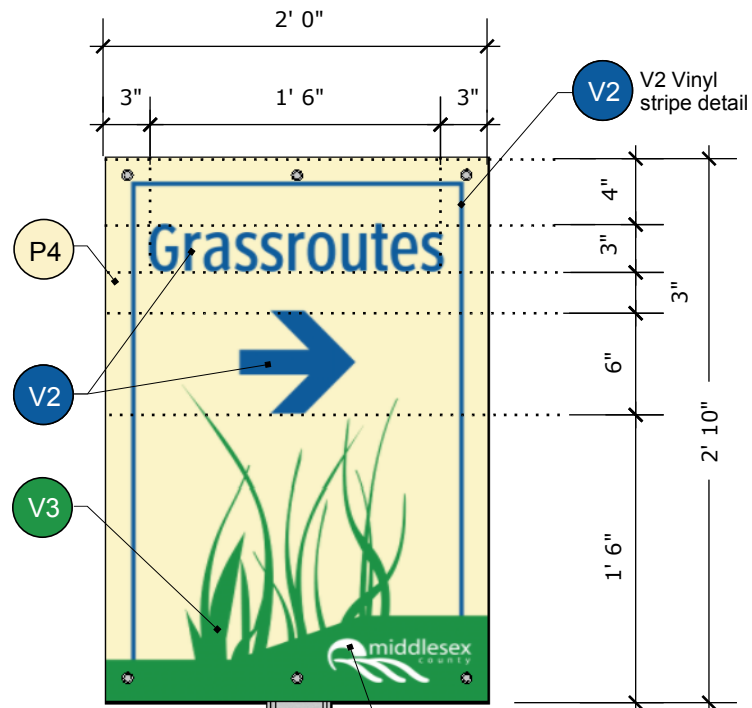

Route Directional Marker

V1 Middlesex logo decal. V1 white vinyl application

3 Font Enlargement
Scale: 1" = 1' (1:12)

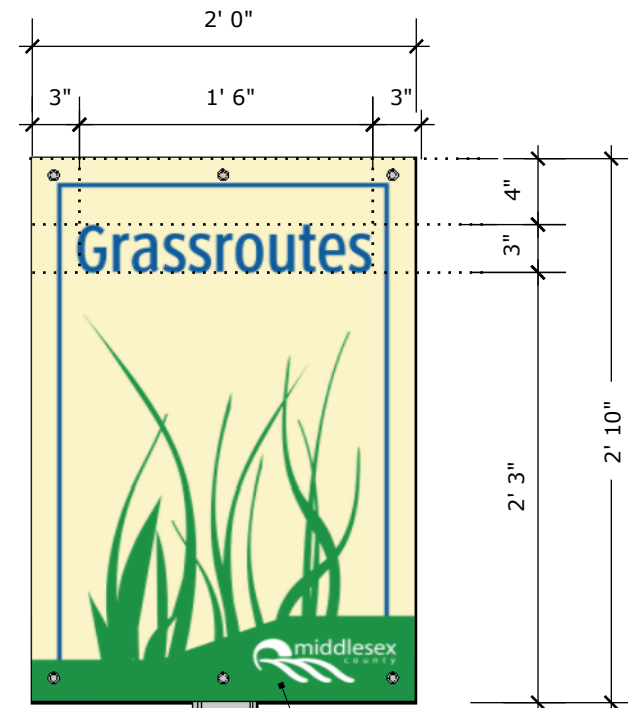

Route Assurance Marker

V1 Middlesex logo decal. V1 white vinyl application

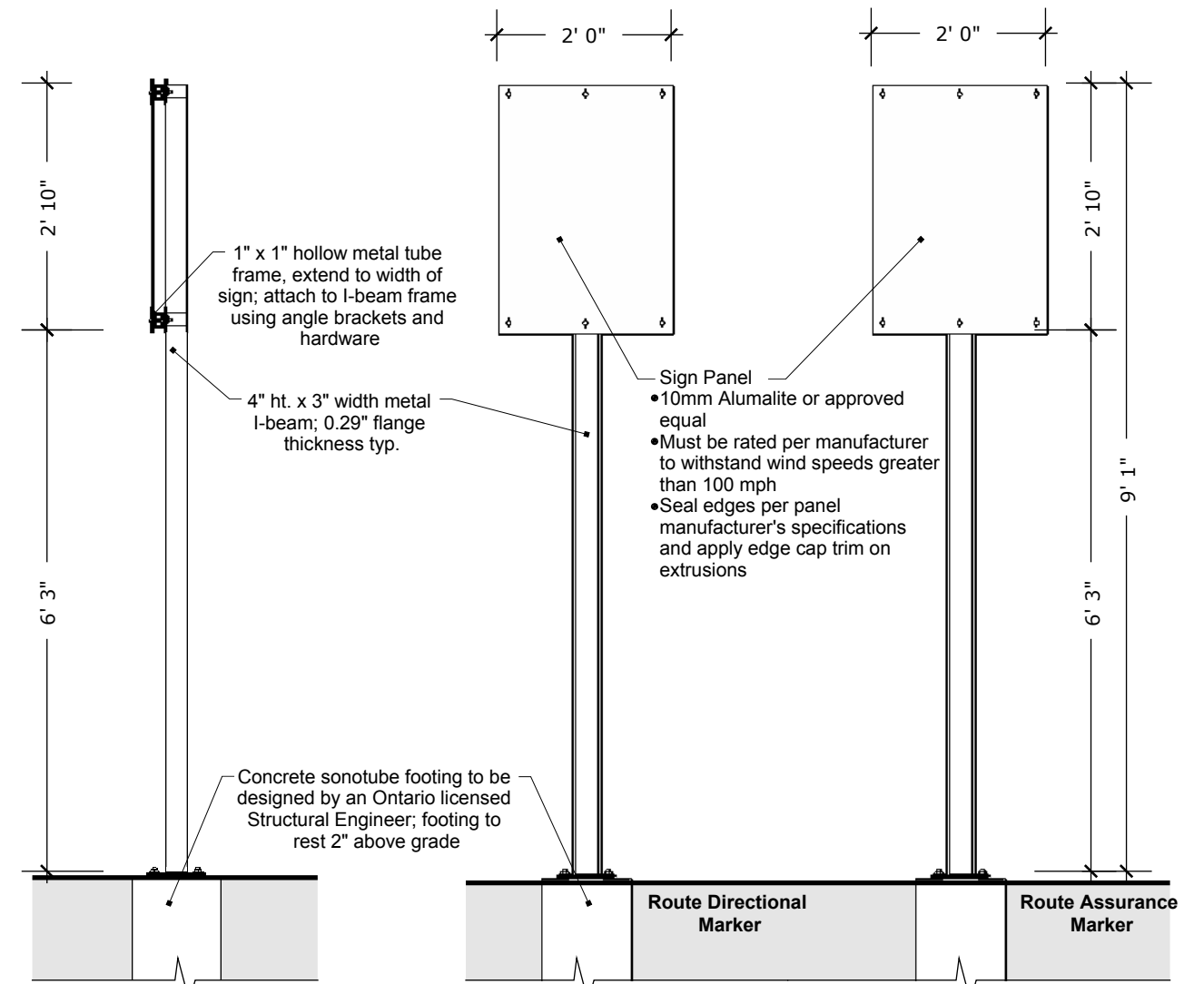

2 Side Elevation
Scale: 1/2" = 1' (1:24)

1 Front Elevation
Scale: 1/2" = 1' (1:24)

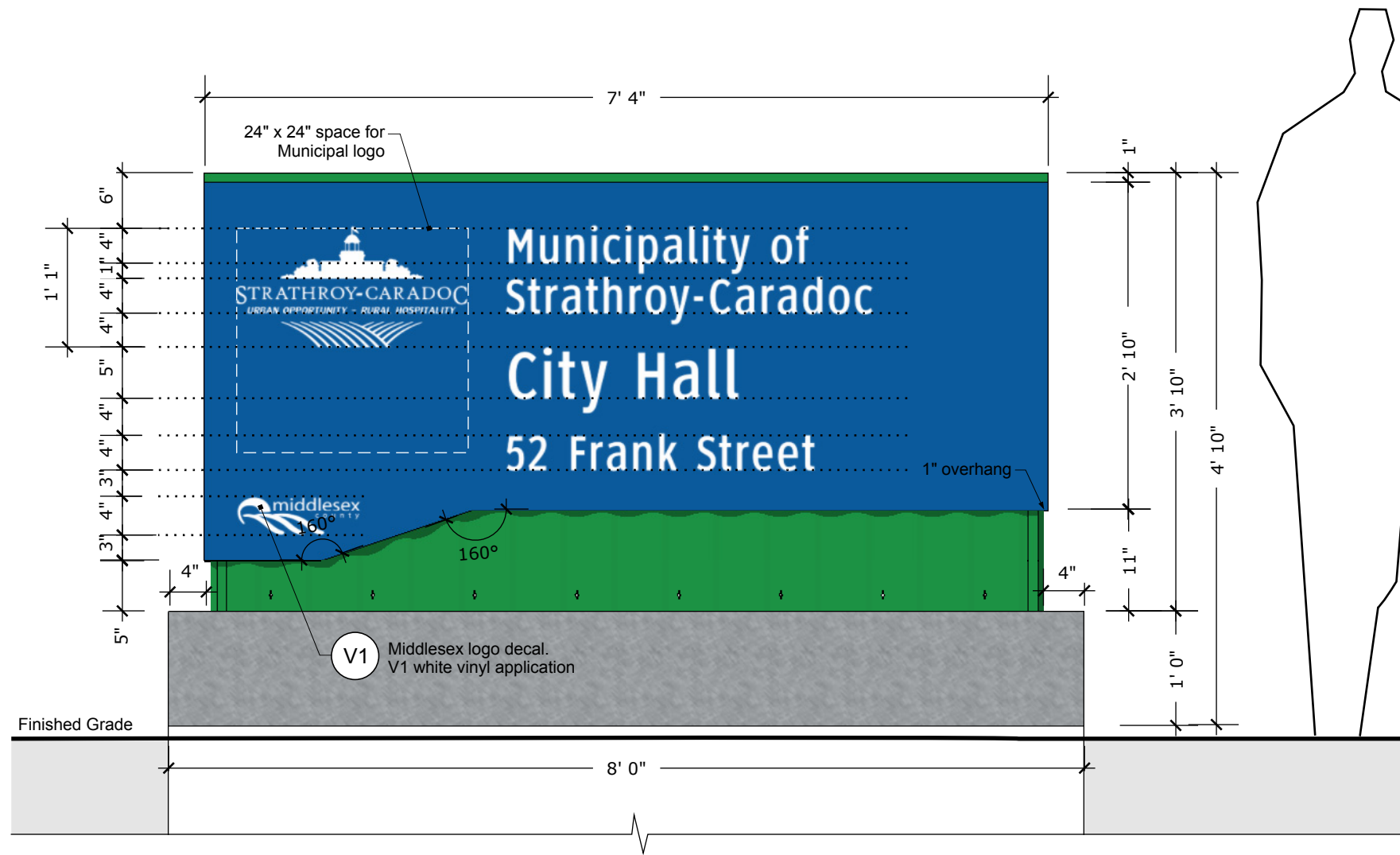

1 Front Elevation
Scale: 3/4" = 1' (1:16)

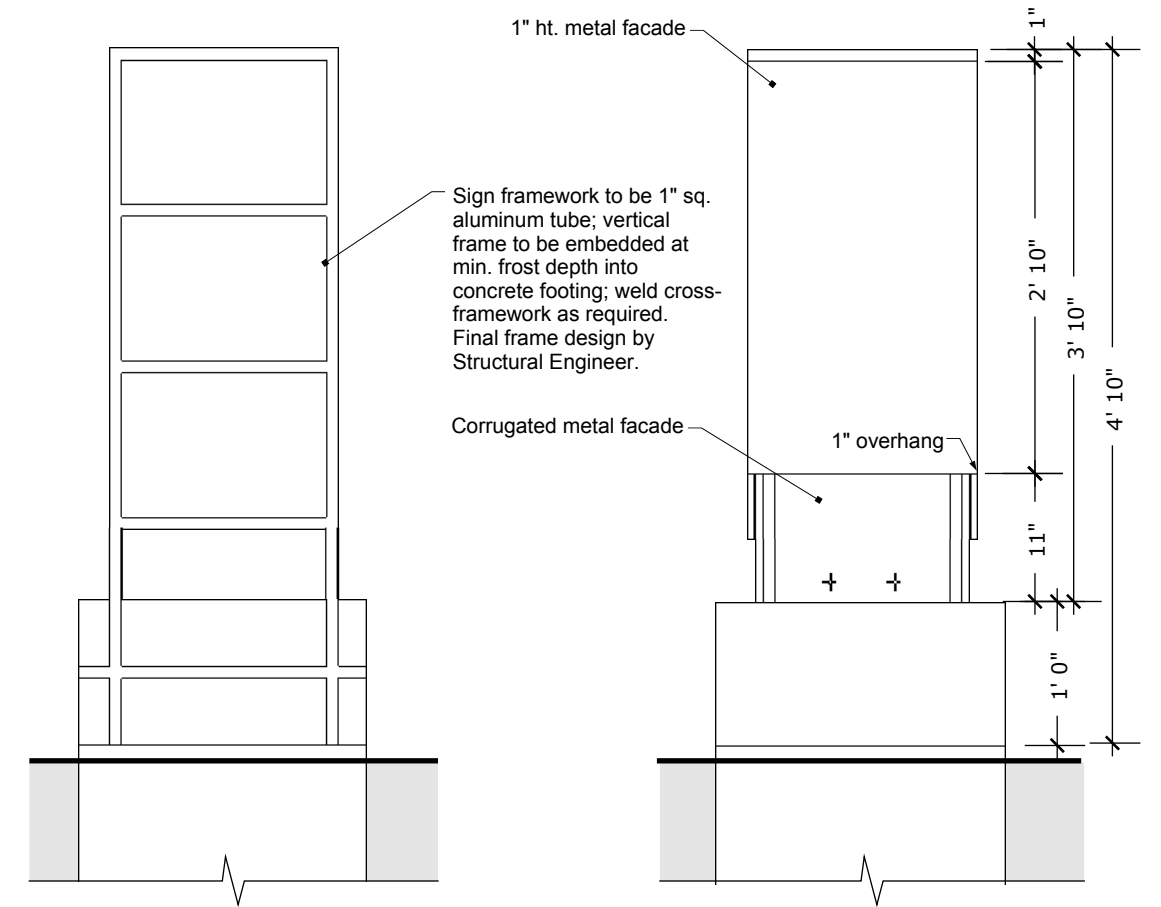

2 Right Side Elevation
Scale: 3/4" = 1' (1:16)

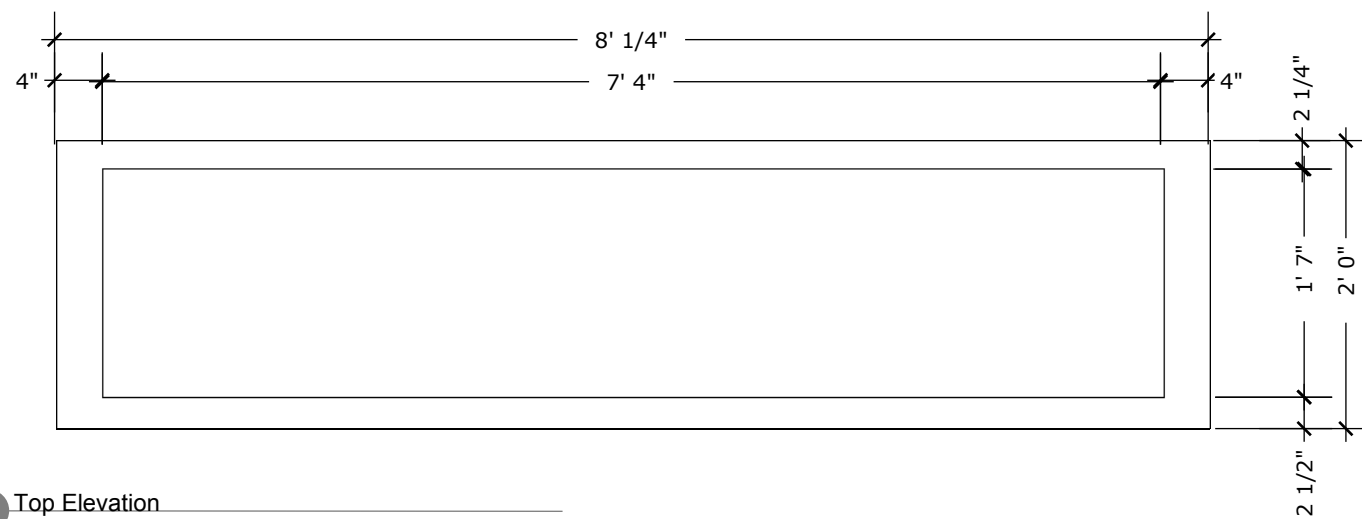

3 Top Elevation
Scale: 3/4" = 1' (1:16)

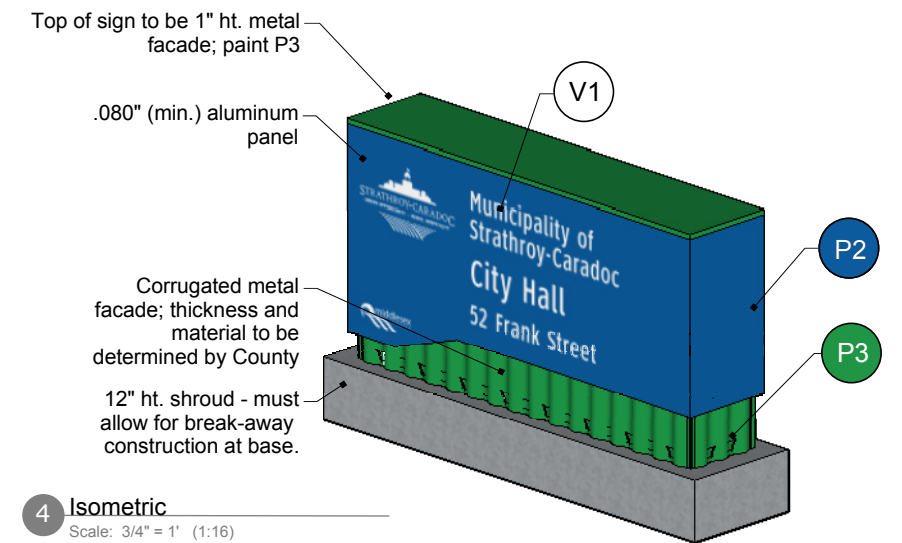

4 Isometric
Scale: 3/4" = 1' (1:16)

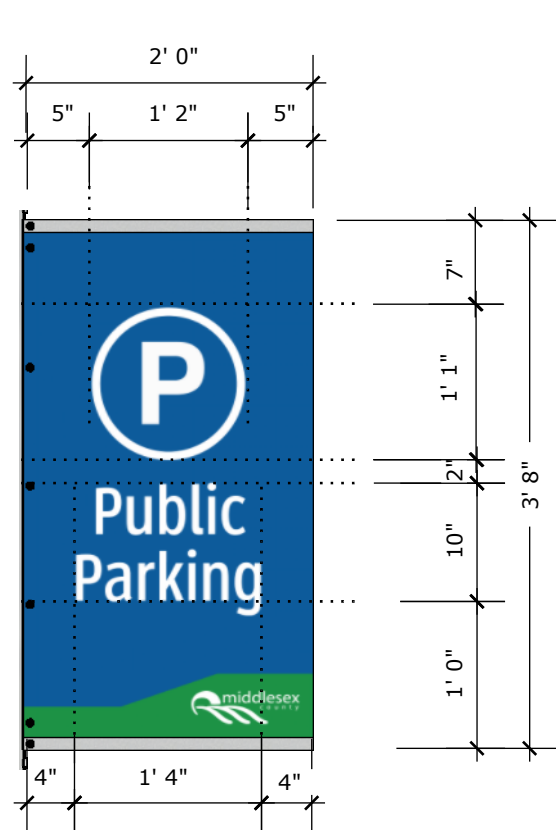

Parking Identification

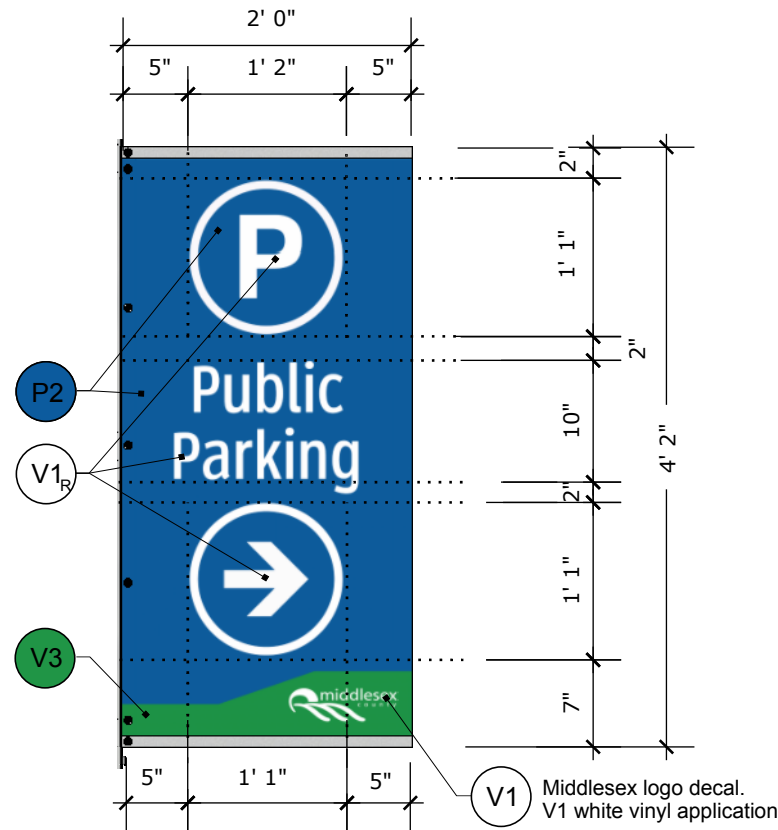

Parking Directional

3 Font Enlargement
Scale: 3/4" = 1' (1:16)

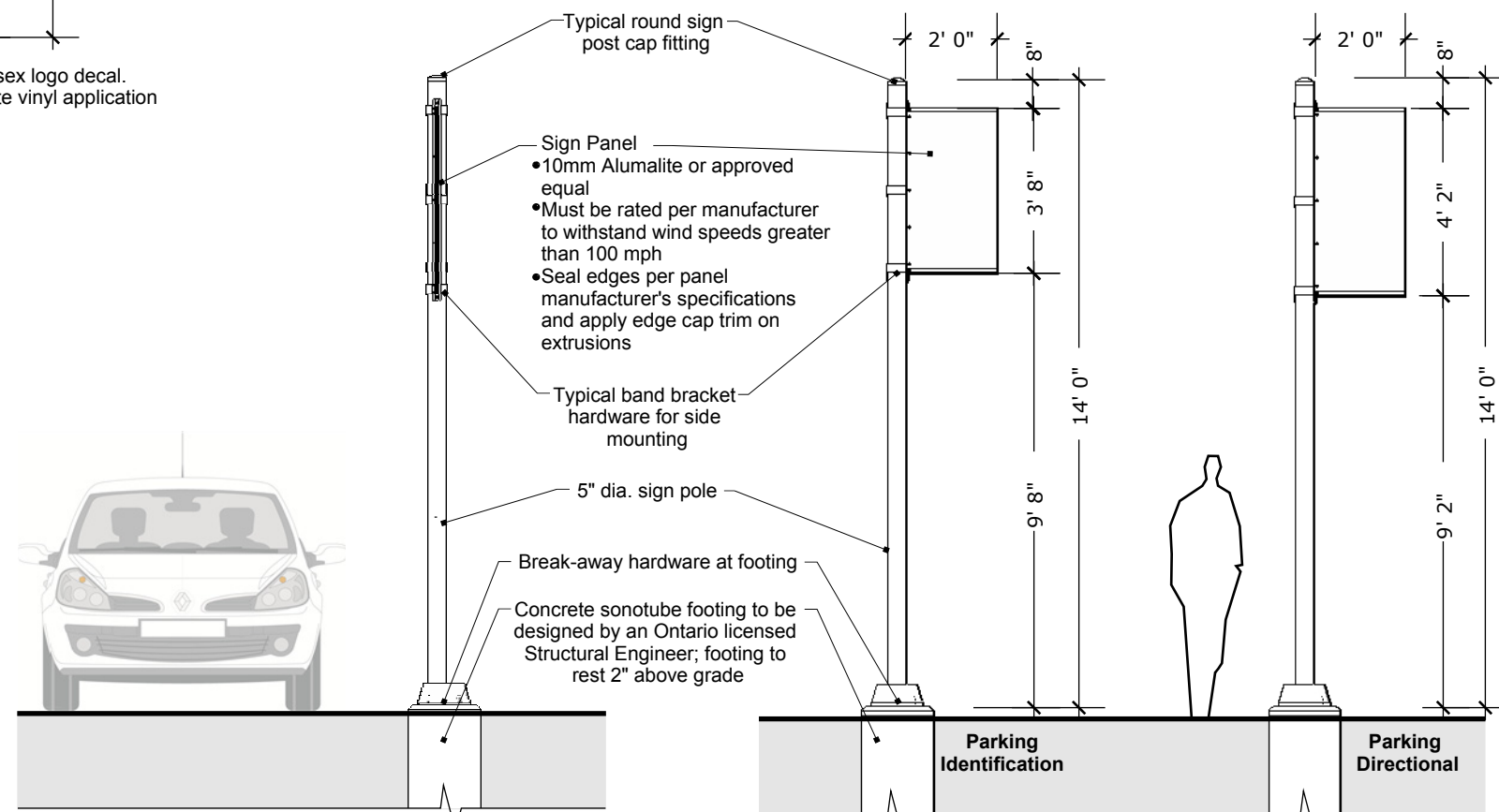

2 Side Elevation
Scale: 1/4" = 1' (1:48)

1 Front Elevation
Scale: 1/4" = 1' (1:48)

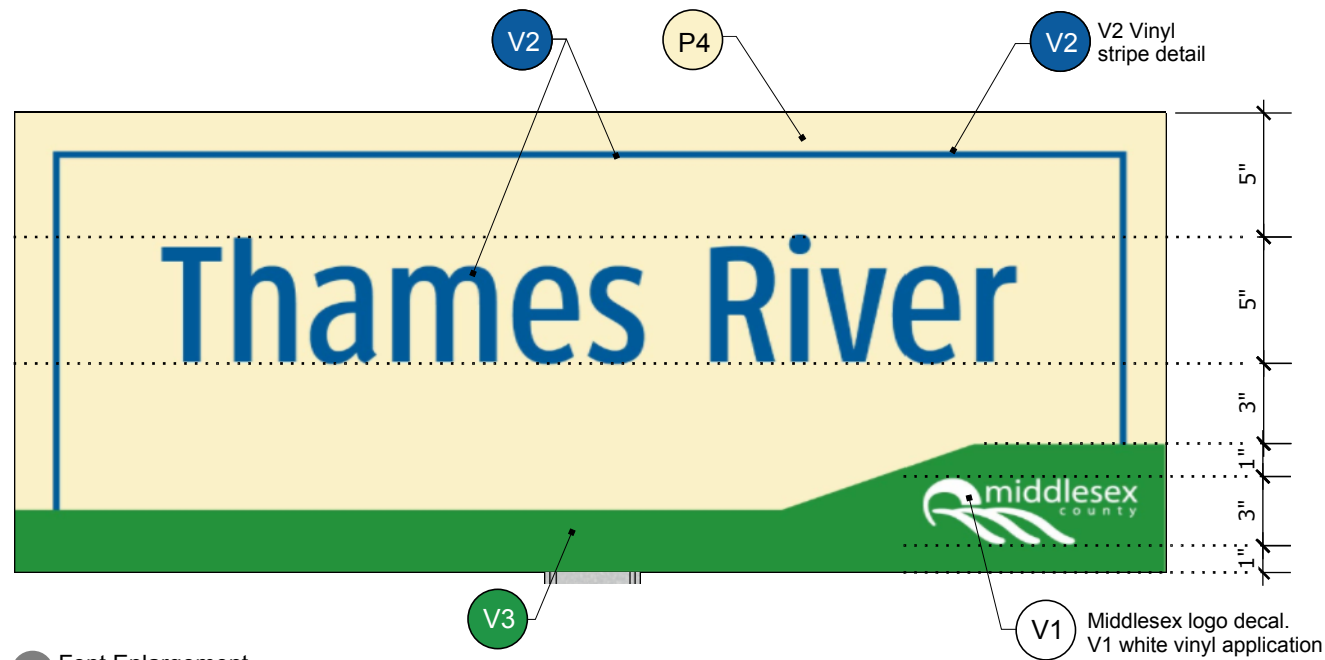

3 Font Enlargement
Scale: 1 1/2" = 1' (1:8)

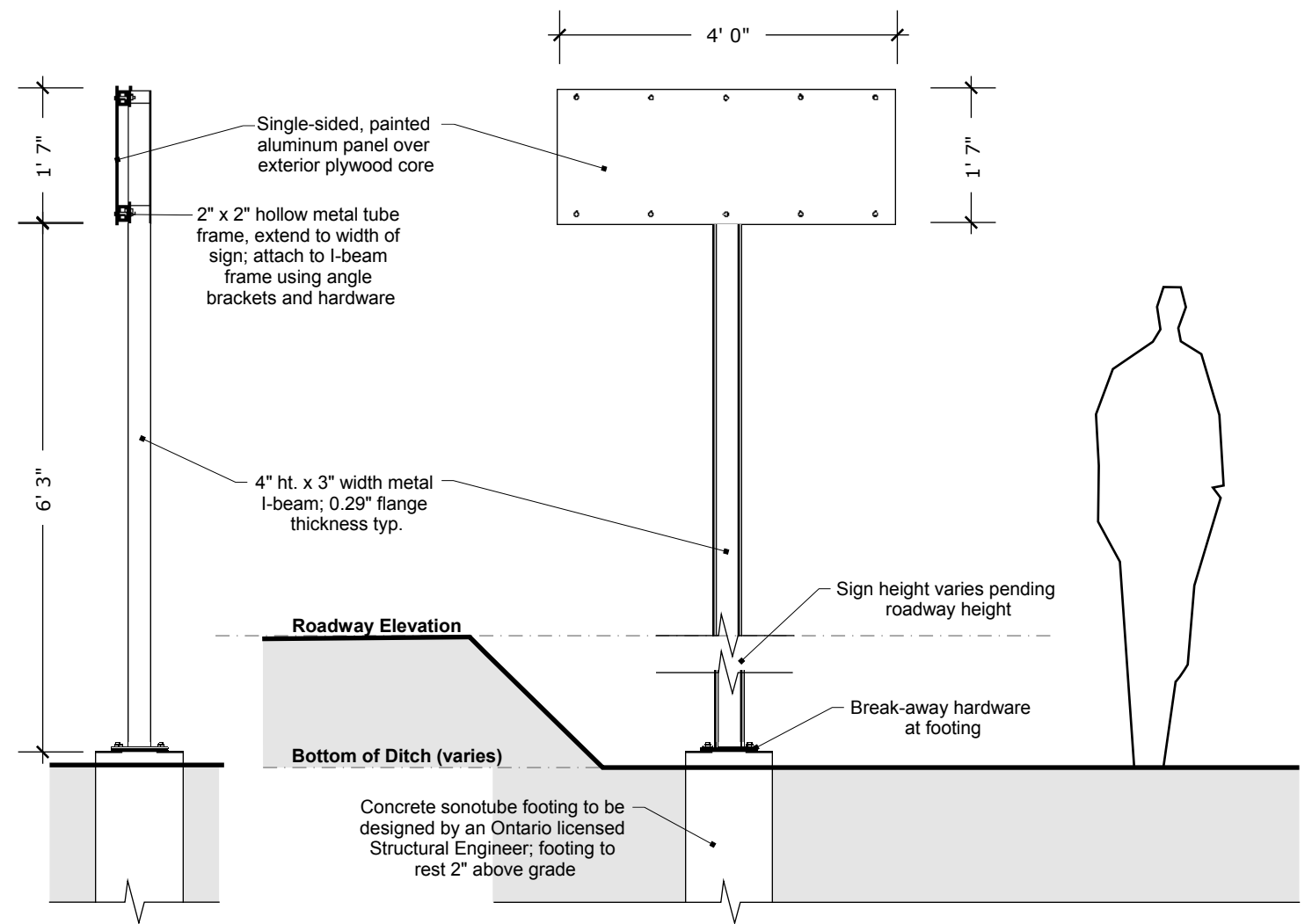

2 Side Elevation
Scale: 1/2" = 1' (1:24)

1 Front Elevation
Scale: 1/2" = 1' (1:24)



Note: Canopy is optional.

Example layout template will be provided. Final layout to be determined by County per specifications and County requirements.

Exterior-grade digital print graphic on .080" thick aluminum. Design to be determined by County; one-side only

Middlesex logo decal. V1 white vinyl application

3 Perspective View
Scale: 1/2" = 1' (1:24)

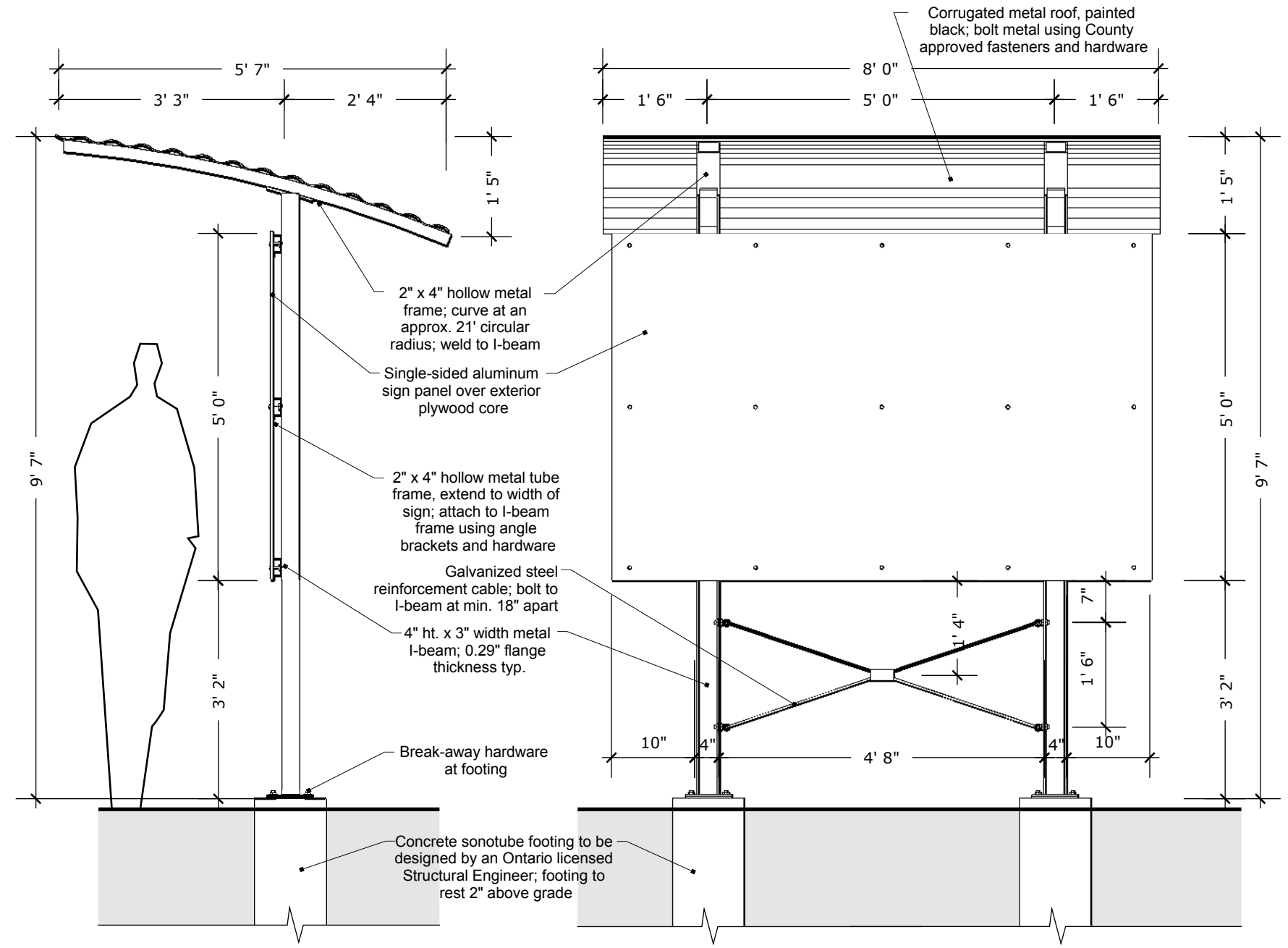

2 Side Elevation
Scale: 1/2" = 1' (1:24)

1 Front Elevation
Scale: 1/2" = 1' (1:24)

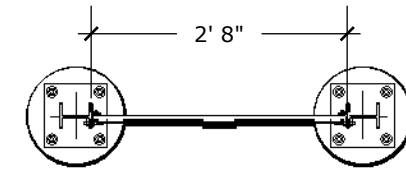

4 Top Elevation
Scale: 1/2" = 1' (1:24)

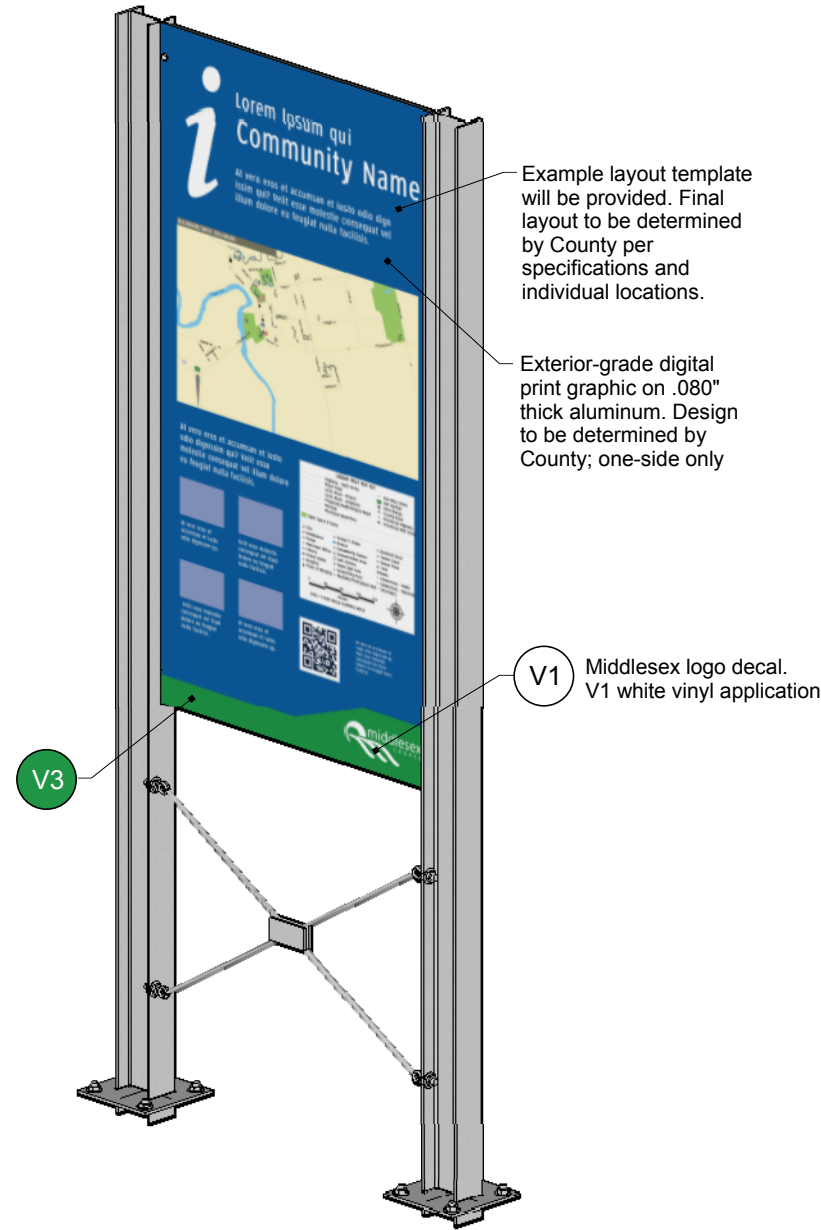

3 Perspective View
Scale: 1" = 1' (1:12)

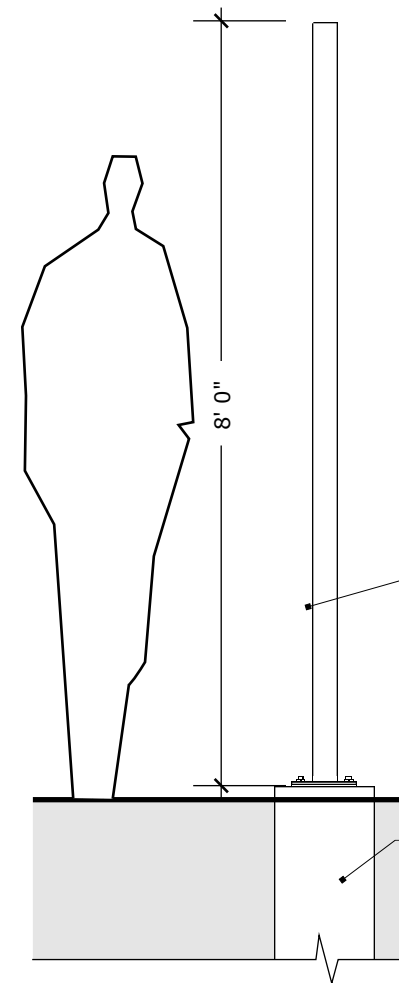

2 Side Elevation
Scale: 1/2" = 1' (1:24)

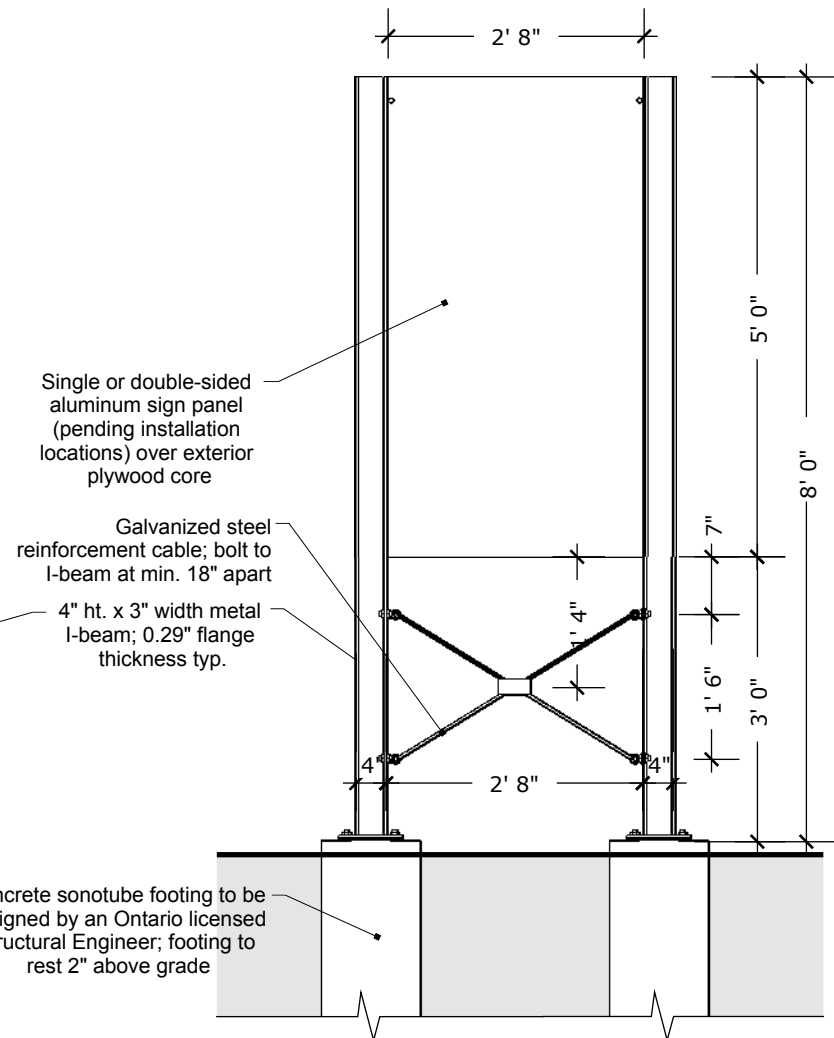

1 Front Elevation
Scale: 1/2" = 1' (1:24)

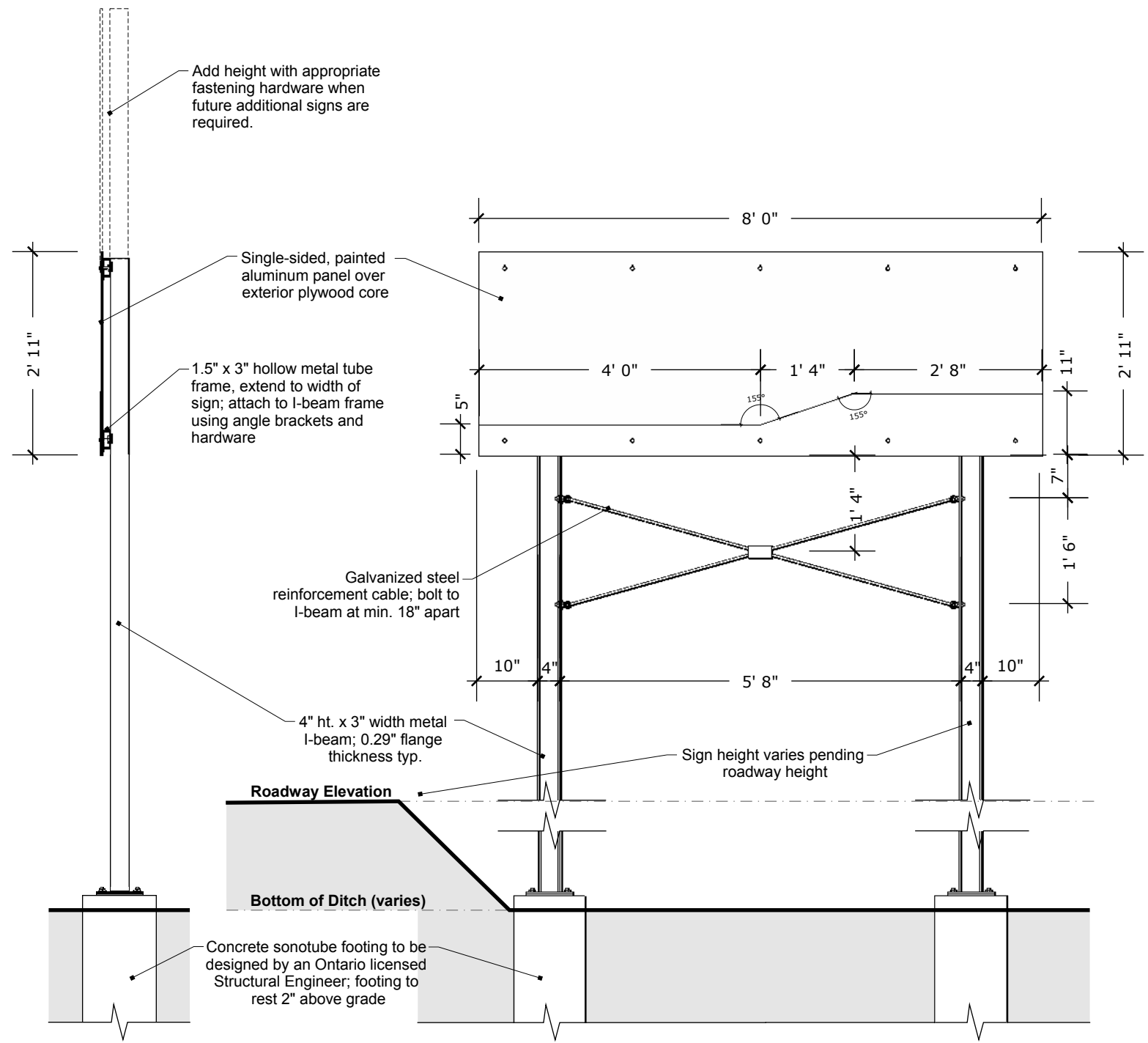
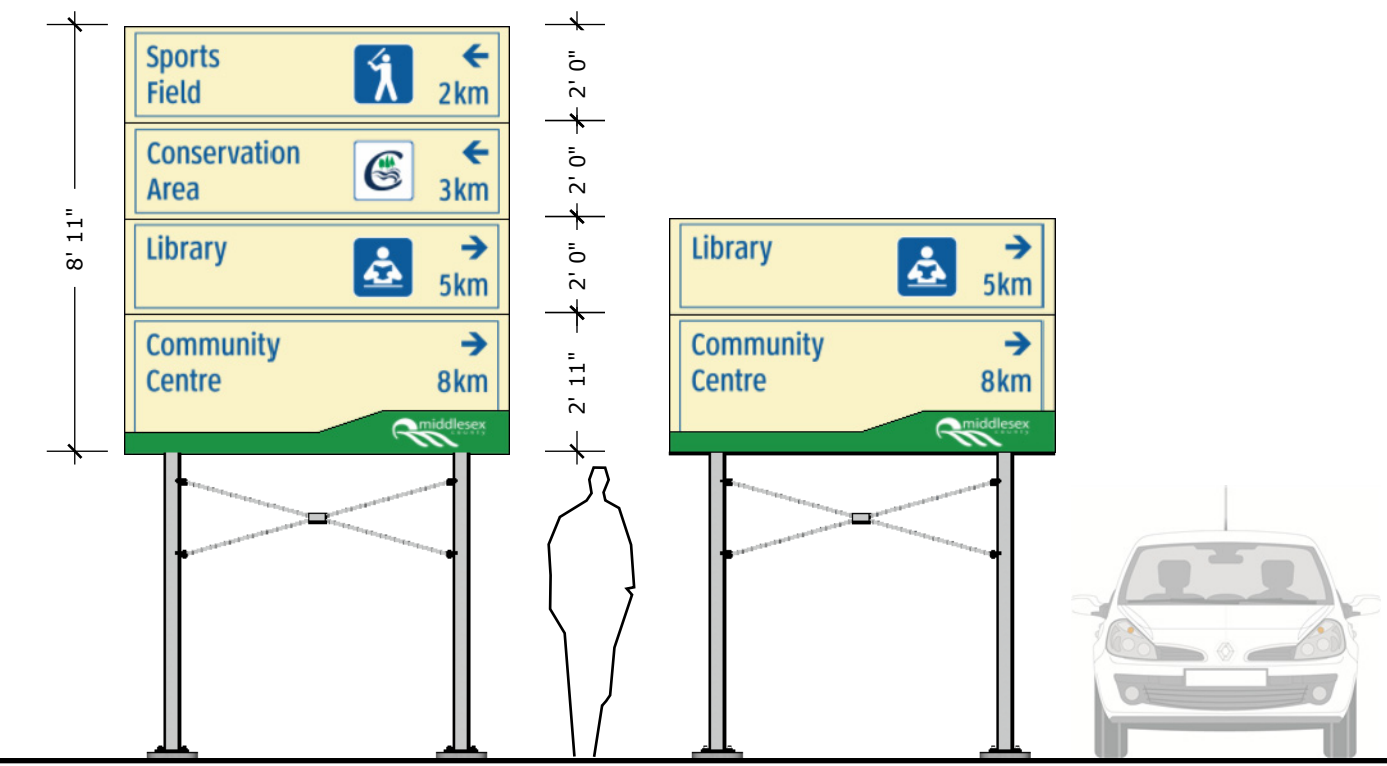
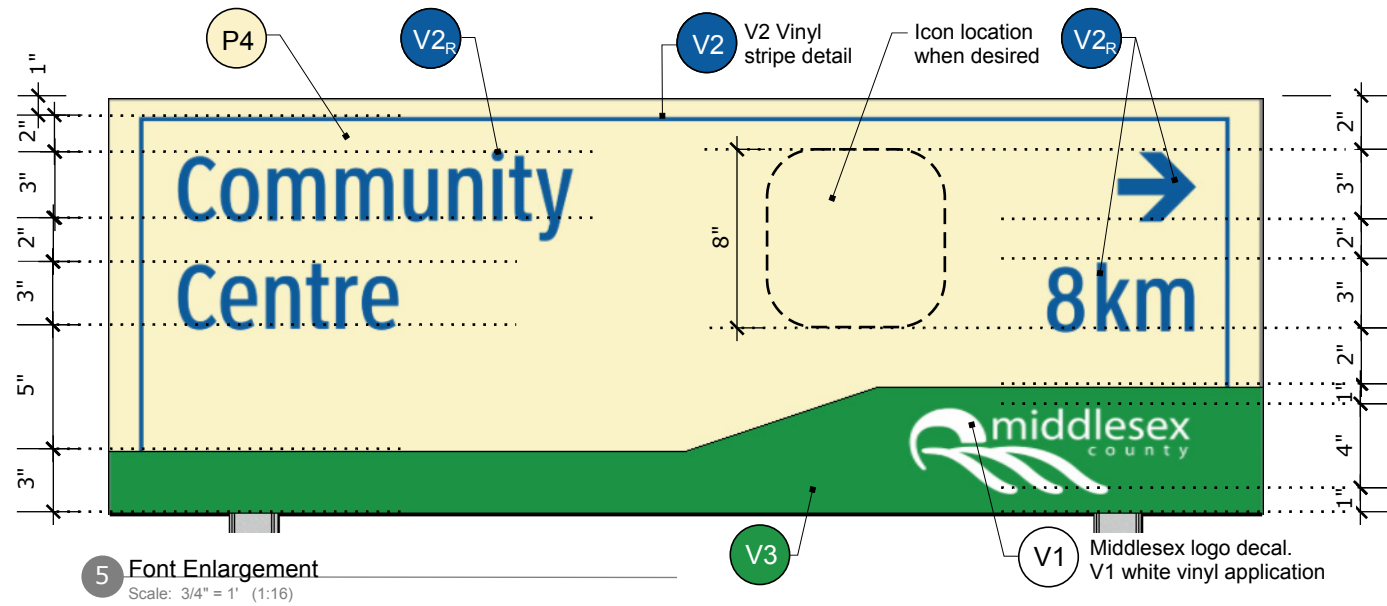

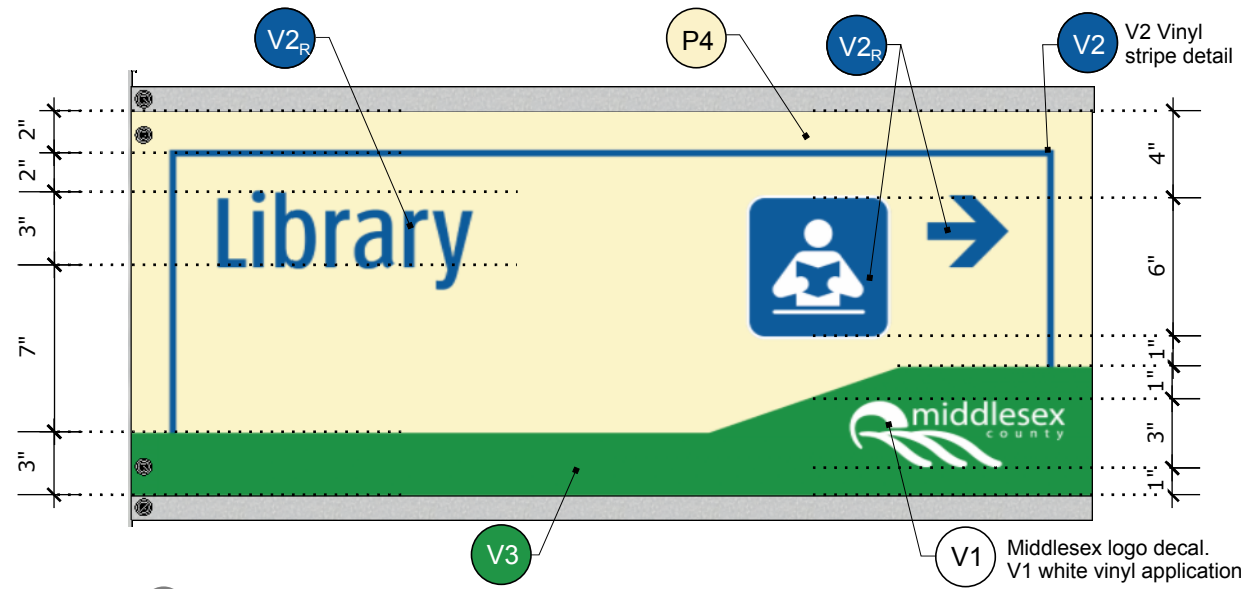

5 Font Enlargement
Scale: 1 1/2" = 1' (1:8)

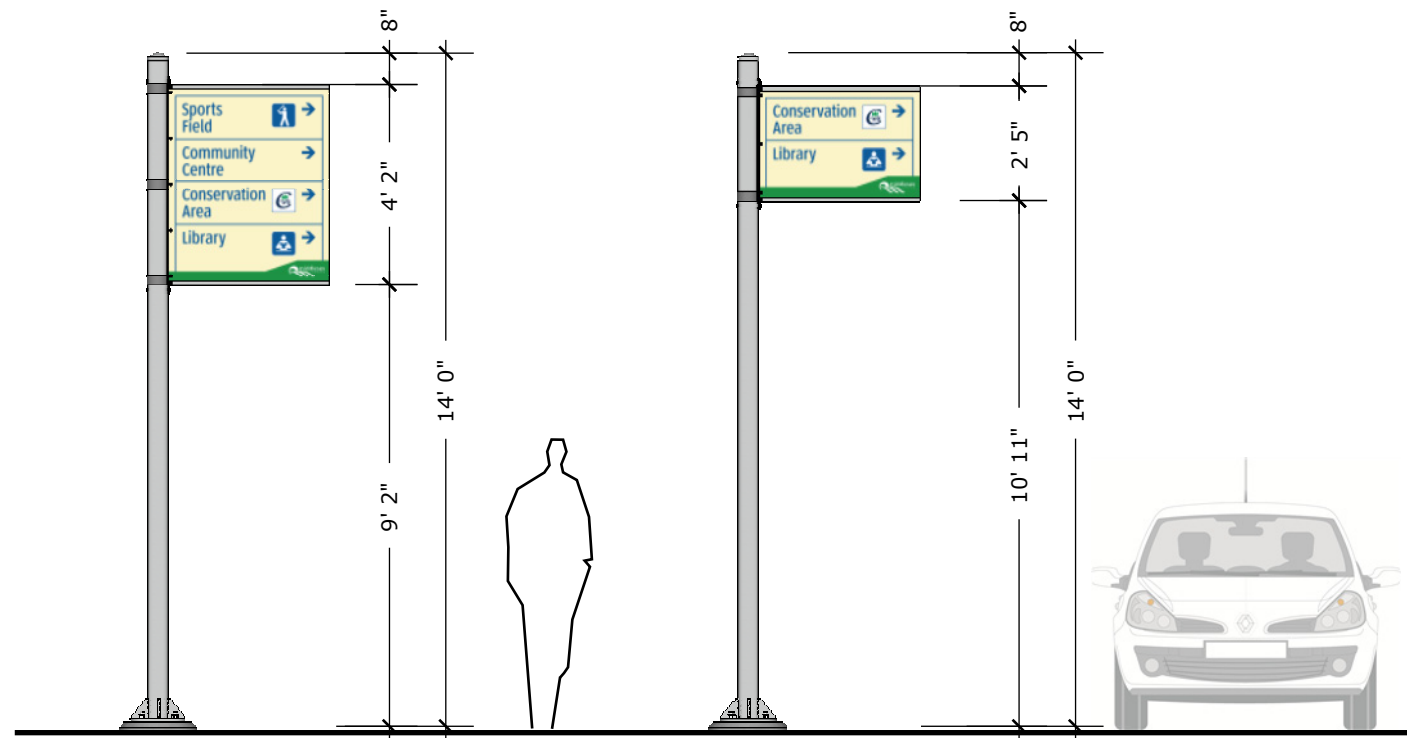

4 Quadruple - Front Elevation
Scale: 1/4" = 1' (1:48)

3 Double - Front Elevation
Scale: 1/4" = 1' (1:48)

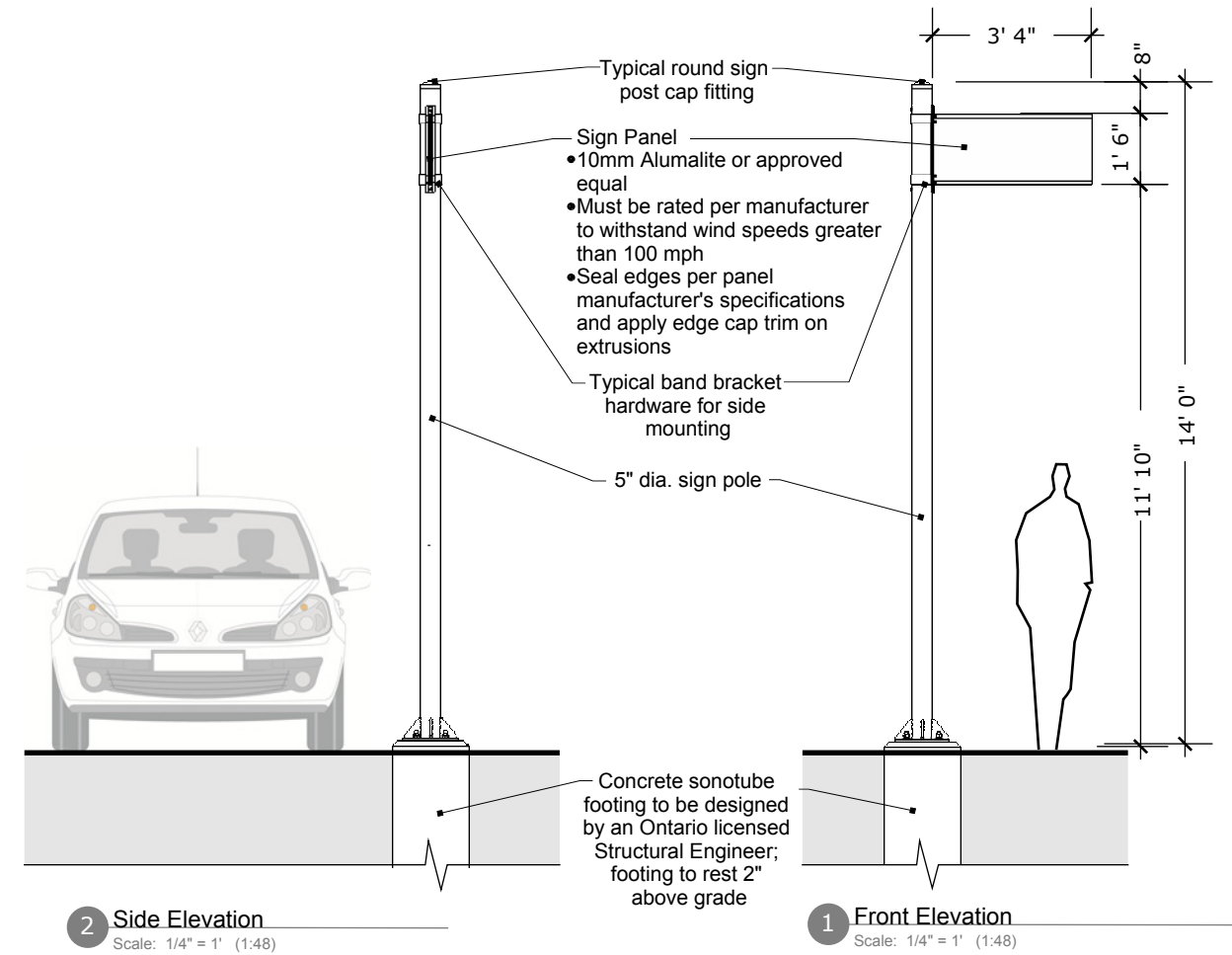

2 Side Elevation
Scale: 1/4" = 1' (1:48)

1 Front Elevation
Scale: 1/4" = 1' (1:48)

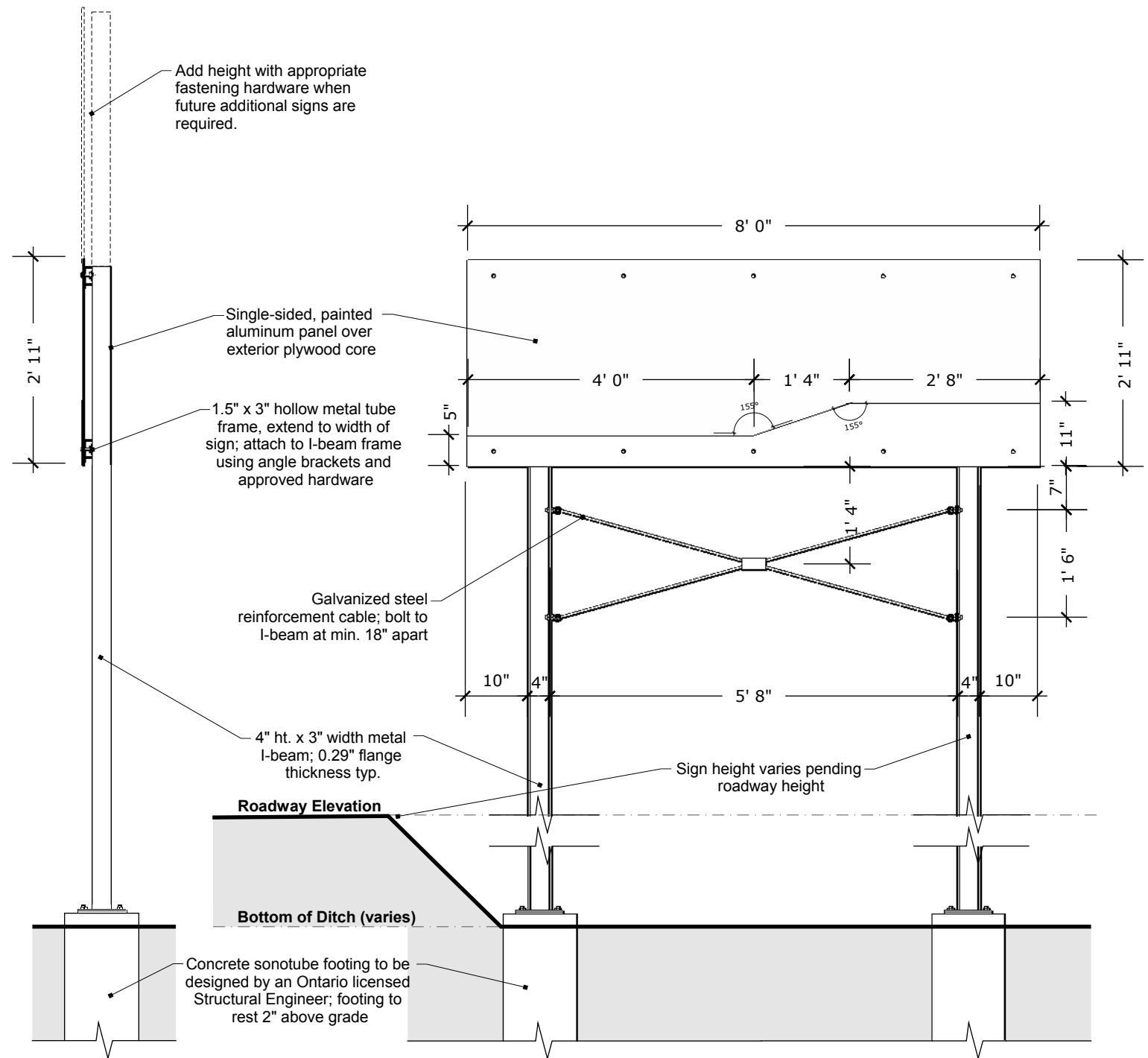
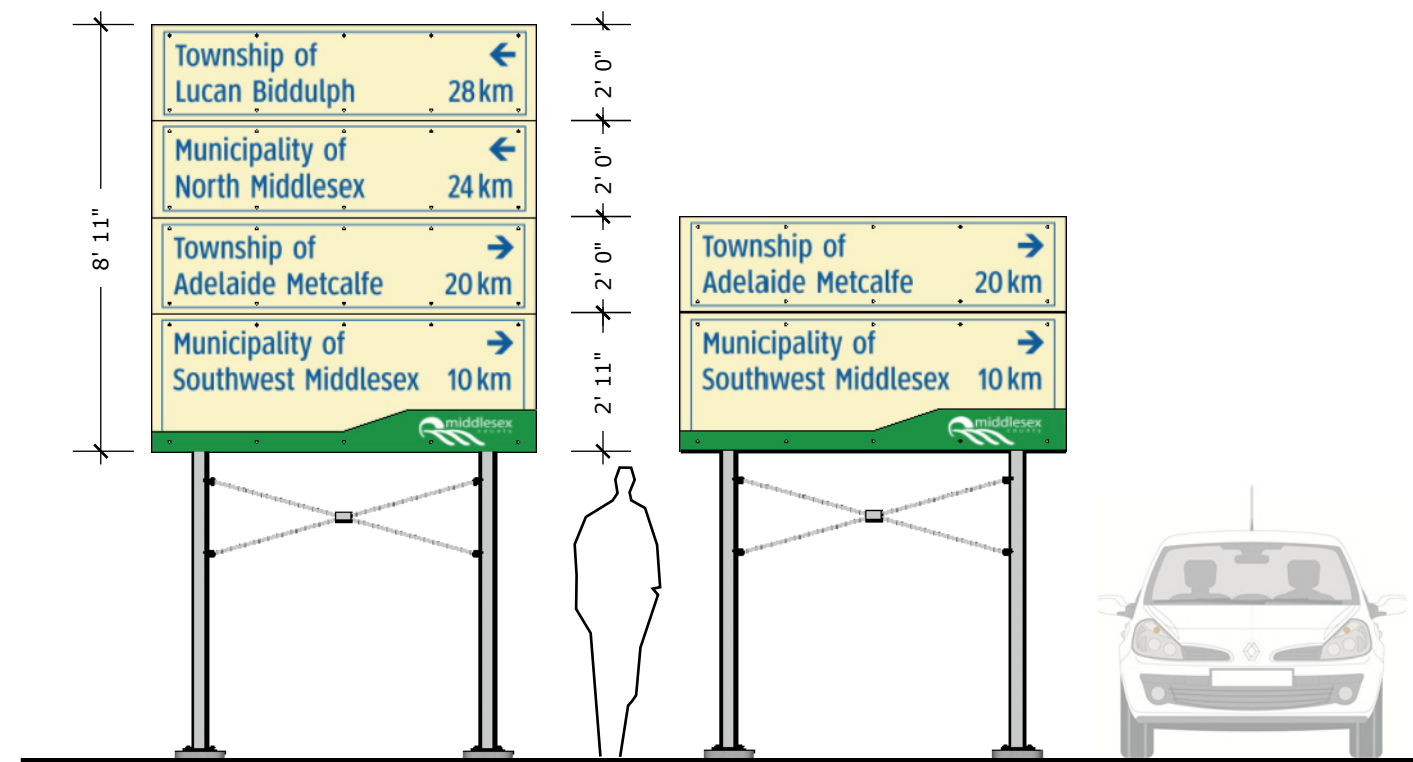
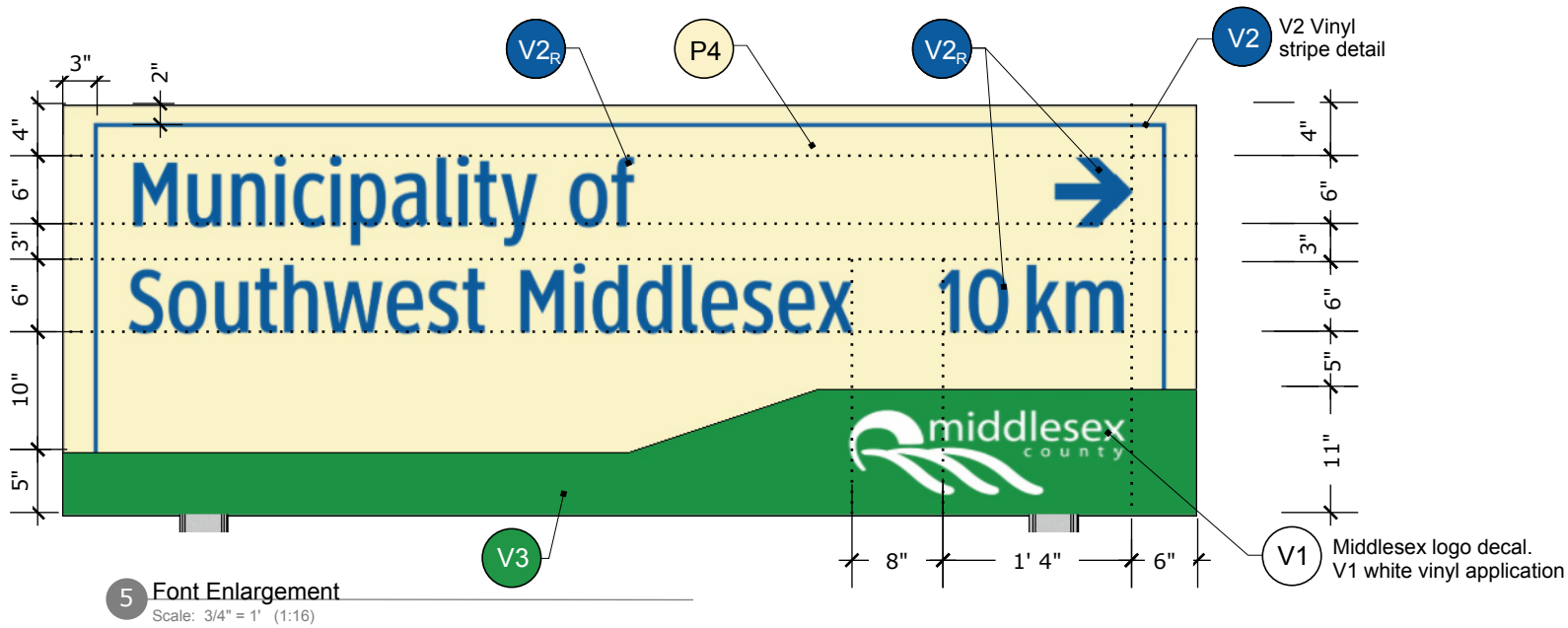

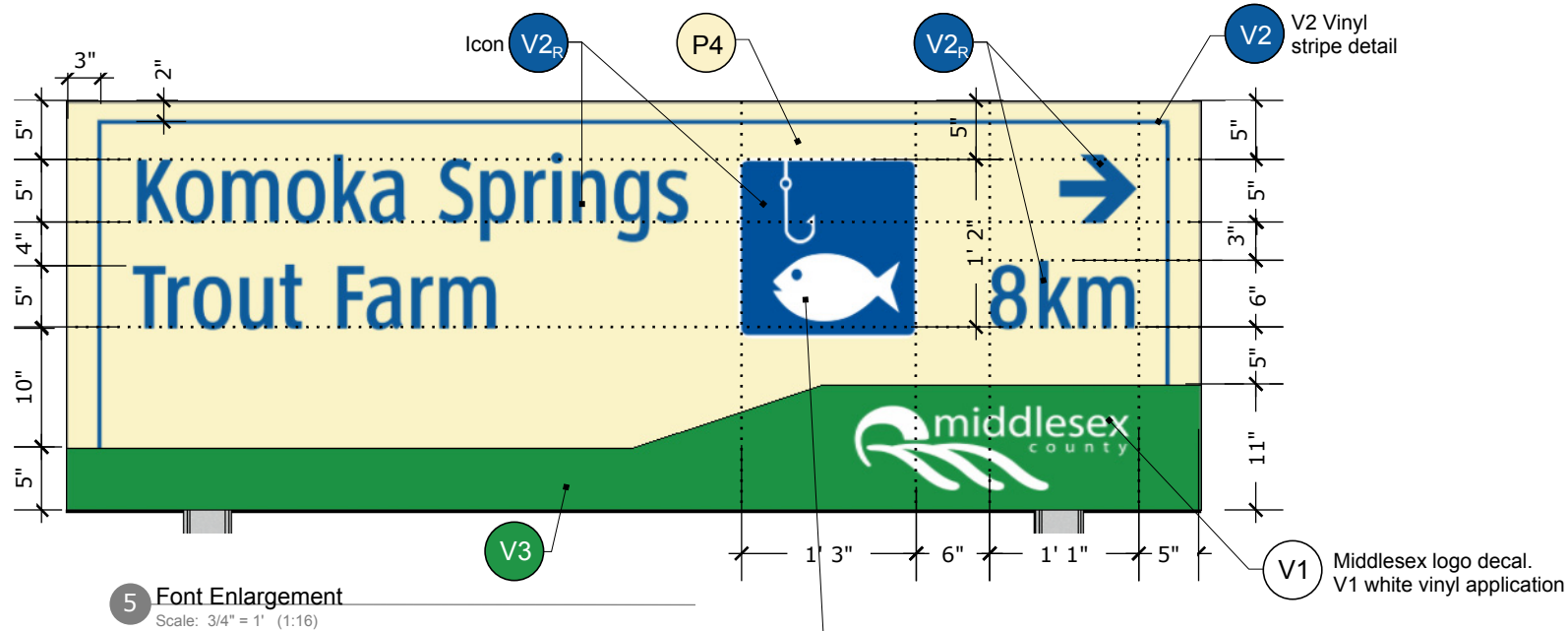

Note: Pay-to-Play users shall have the option to use their own logo instead of a pictogram on the condition that the logo appears in blue and white and fits within the 15" x 15" space.

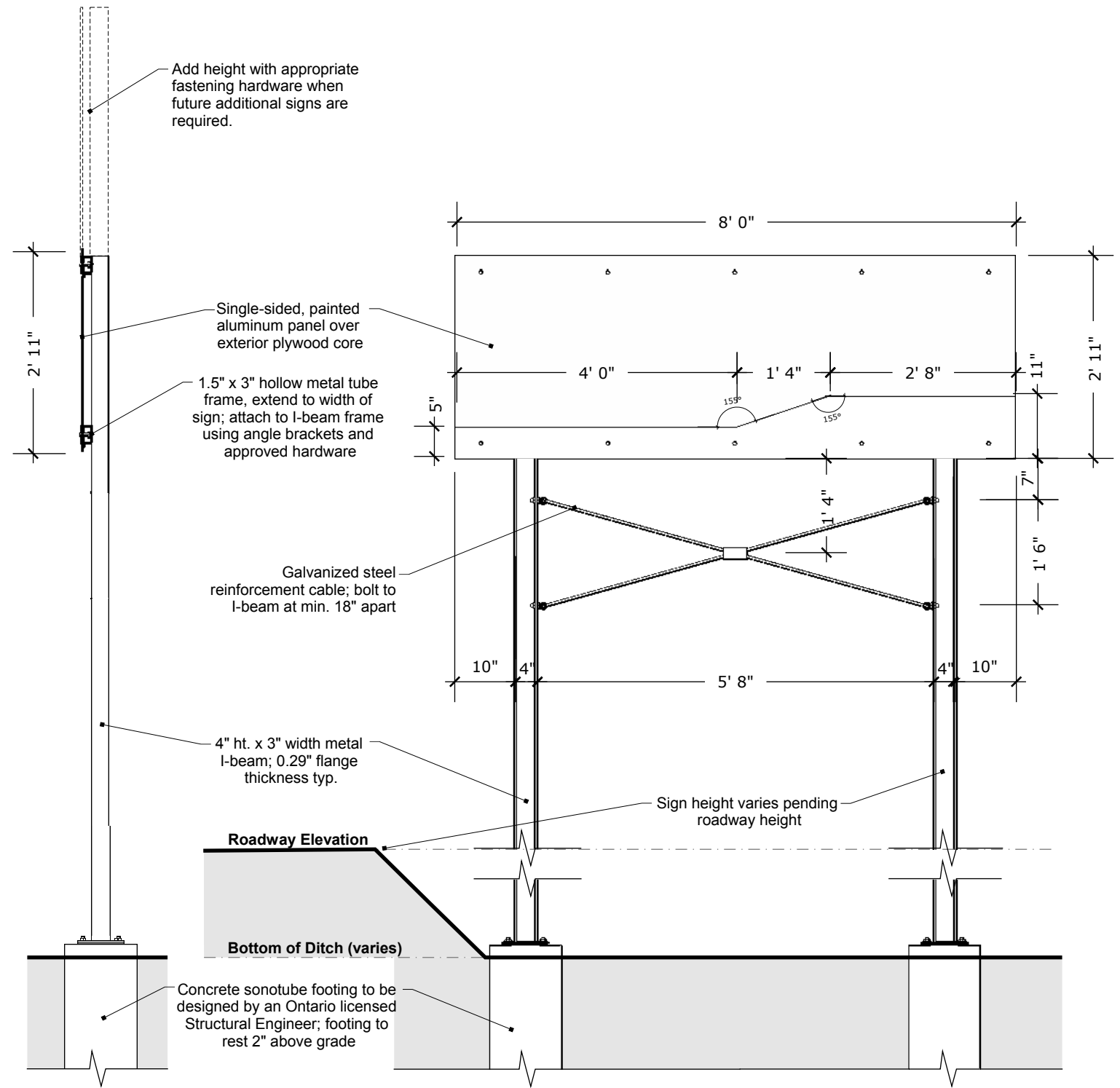
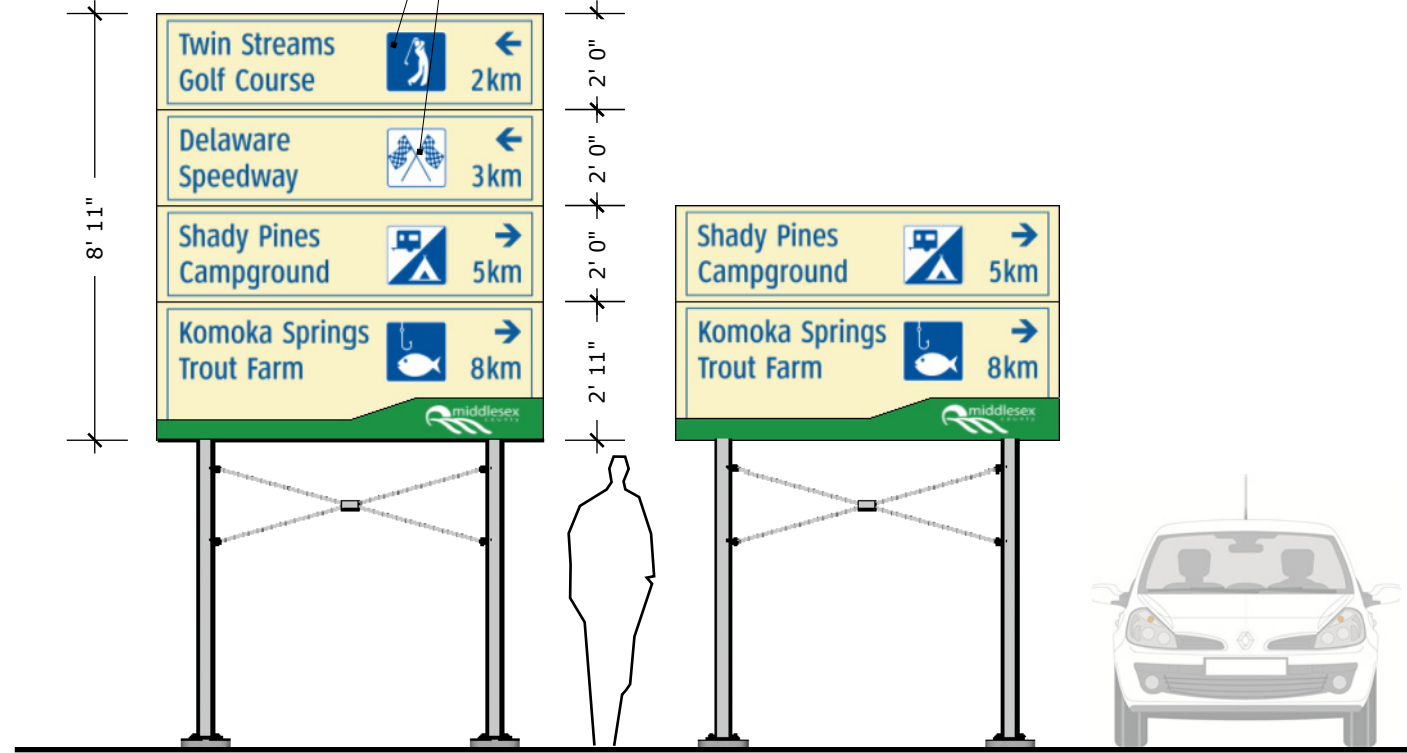

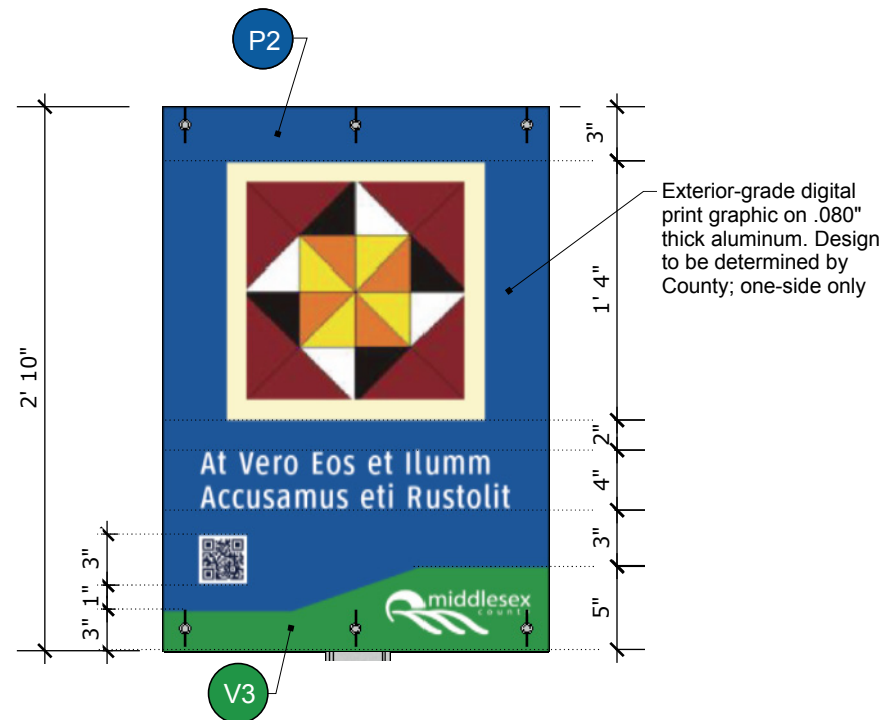

3 Font Enlargement
Scale: 1" = 1' (1:12)

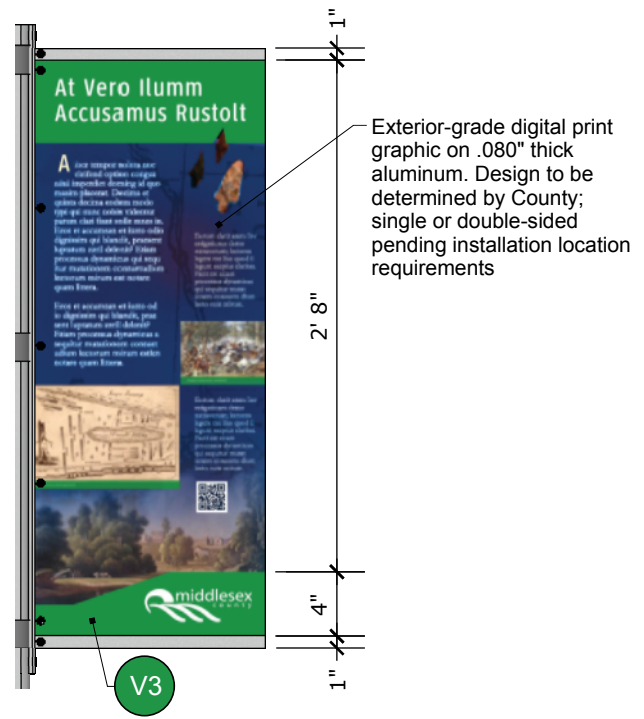

3 Layout Detail
Scale: 3/4" = 1' (1:16)

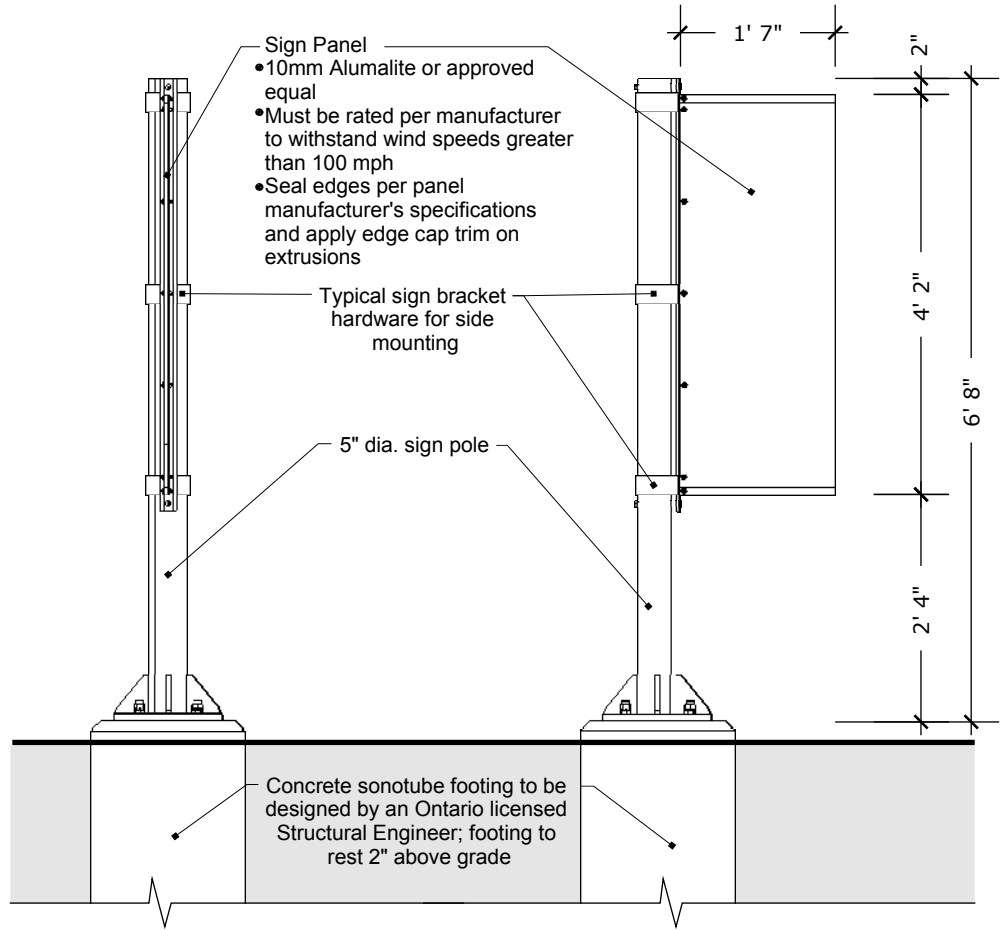

1 Side Elevation
Scale: 1/2" = 1' (1:24)

2 Front Elevation
Scale: 1/2" = 1' (1:24)

Interpretive Panel

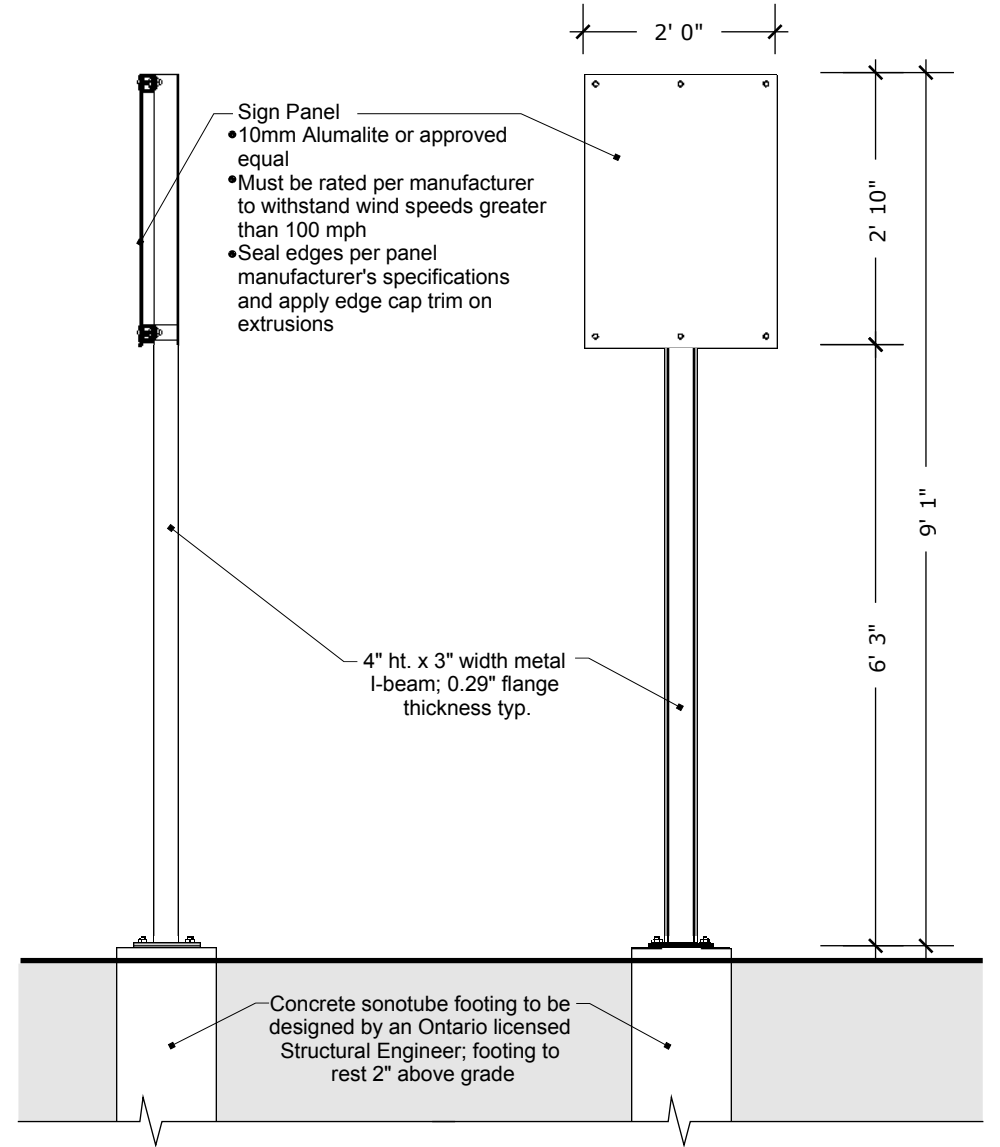

2 Side Elevation
Scale: 1/2" = 1' (1:24)

1 Front Elevation
Scale: 1/2" = 1' (1:24)

Interpretive Marker

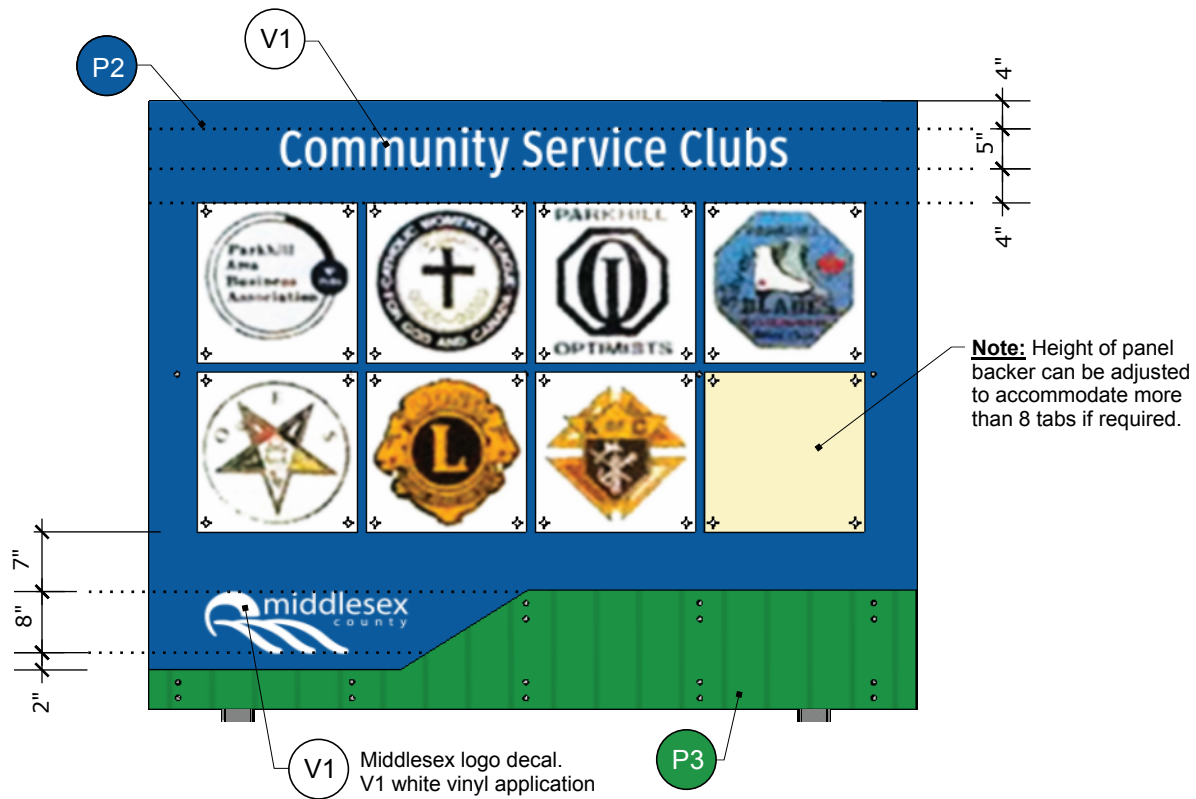

3 Layout Detail
Scale: 1/2" = 1' (1:24)

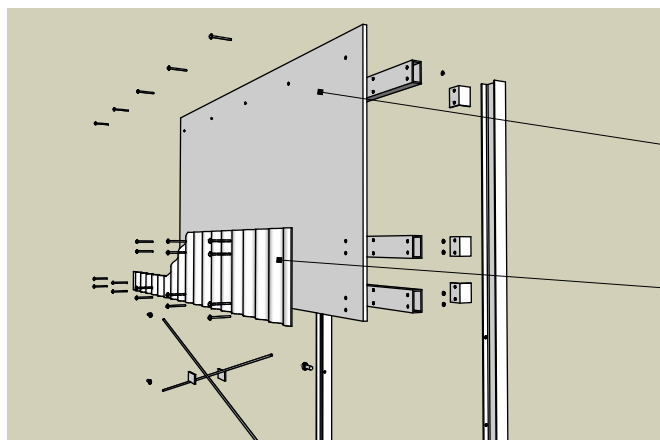

Fabrication Option 1

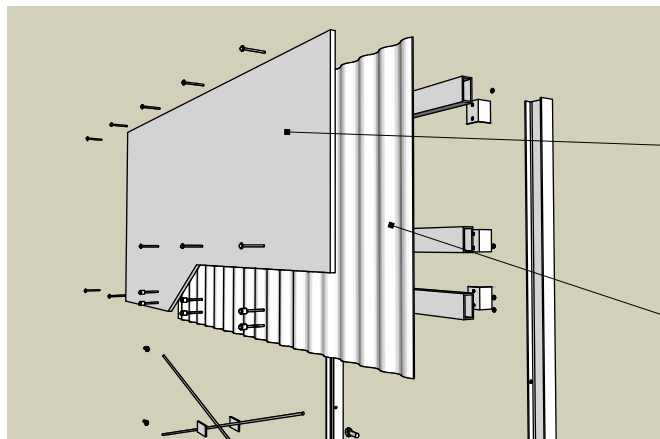

Fabrication Option 2

Note: The Municipality is required to choose a fabrication option best fit for their in-house capabilities upon the implementation stage of the project. Once an option is chosen, it must be applied to all future signs for consistency.

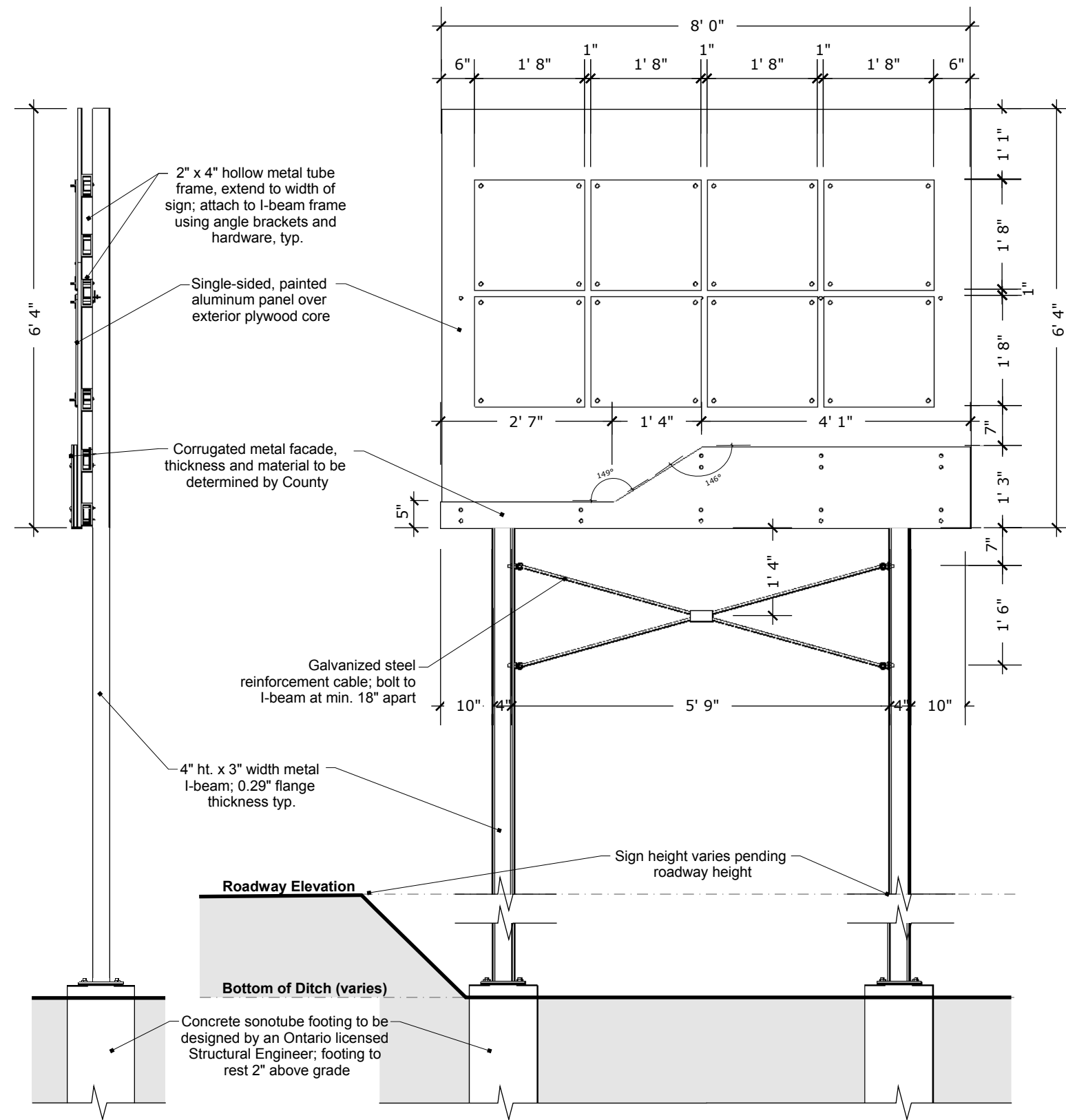

2 Side Elevation
Scale: 1/2" = 1' (1:24)

1 Front Elevation
Scale: 1/2" = 1' (1:24)

 *form:*media



www.form-media.ca